

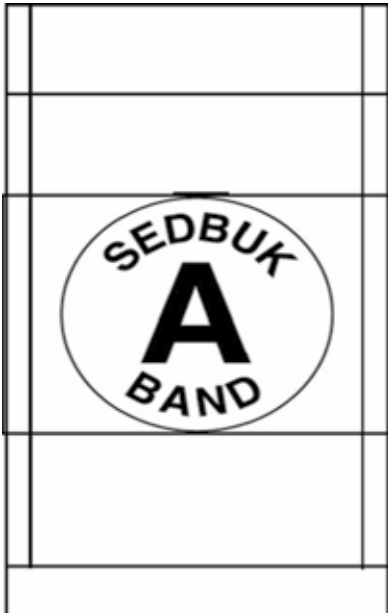

Condensing Range

Oil Fired Boilers You'll Warm To

Customer Information. Installation And Servicing Manual



Condensing Oil Fired Floor standing Boilers.

Models covered by this manual:

| | |
|----------------------------------|-----------------|
| Blue flame Low-Nox | 15-58 kw |
| Internal Combination | 15-41 kw |
| Internal Mega Combination | 41-70 kw |
| Internal Sealed System | 15-41 kw |
| Kitchen/Utility | 15-70 kw |
| Outdoor Combination | 15-41 kw |
| Outdoor Mega Combination | 41-70 kw |
| Outdoor Sealed System | 15-41 kw |
| Outdoor Standard | 15-70 kw |
| Boiler House | 15-70 kw |
| Non Condensing Range | 15-70 kw |

Please Leave These Instructions with the User

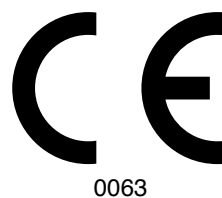

Mistral manufacture a comprehensive range of Sedbuk A rated high efficiency oil boilers for domestic and industrial heating applications. Culminating from years of experience, ongoing development and our wealth of technical knowledge the specially developed Mistral “Y” section heat exchangers are fitted to all Mistral condensing and non condensing boilers providing much improved performance and operating efficiency.

The unique “Y” section centrally located waterway design allows excellent heat transfer to take place, particularly in the lower combustion chamber. This greatly reduces the pressure build up normally associated with conventionally manufactured boiler types. The “Y” section design allows baffles to be a more open tolerance, providing for better overall running performance, smoother start ups and cleaner combustion. Baffles fitted to non central waterway heat exchangers, normally have to be extremely tight to attain required efficiencies, which can cause pressure build up and increase soot deposit in the boiler.

The additional surface heat transfer area created within the boiler by the “Y” section heat exchanger also allows Mistral to manufacture high KW output boilers within typical domestic appliance size enclosures. Mistral Energy Products Limited is committed to offering the most technically advanced and extensive range of domestic oil fired boilers available.

INNER Y SECTION

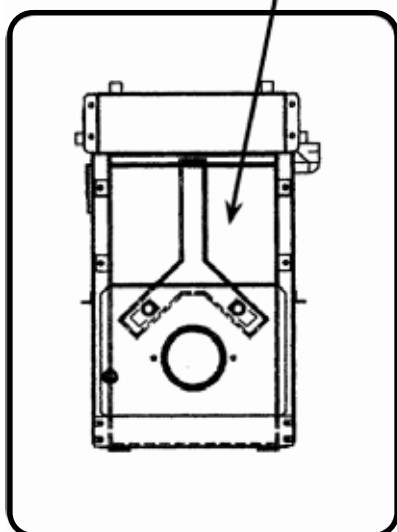

BLUE FLAME LOW-NOX BURNER

Why low Nox

Nox is the term used to describe Nitrous oxide which is released during normal combustion. When combined with water and released into the atmosphere it produces acid rain, and results in significant long term damage to any structure that is repeatedly exposed to it.

NOx combines with other substances and creates smog when it is exposed to sunlight. This creates a major health hazard for people that live in affected areas. NOx penetrates into the lung tissue and can cause permanent damage. Children, the elderly, people with asthma and other breathing difficulties, and people that work outside are especially susceptible to the negative health effects of NOx.

The way to reduce that health risk is for companies to employ NOx reduction measures.

WARRANTY

Heat Exchanger - 5 Years
Burner & Controls - 1 Year
(Terms & Conditions apply)

SAFETY

Please note that the products are extremely heavy and great care should be taken when moving the appliance around. Specialist equipment should be used where possible, a full risk assessment and a plan of action should be undertaken, prior to purchase to avoid any injury.

INDEX / PAGE CONTENTS

| | | |
|-------------|--|-------|
| 1.0 | Health and safety | |
| 1.1 | COSHH | 4 |
| 1.2 | In The Event of a Spillage | 1.3 |
| | Operation | |
| 2.0 | User Information | |
| 2.1 | Introduction | 5 |
| 2.2 | Product Description | 5 |
| 2.3 | Pre Install Procedure | 5-7 |
| 2.3 | Specifications And Physical Dimensions | 8-9 |
| 2.4 | Heating And Hot Water connection | 10 |
| 2.5 | Safety..... | 12 |
| 2.6 | Oil Supply | 12 |
| 2.7 | Electrical Connection | 12 |
| 2.8 | Useful Information | 12 |
| 2.9 | Air Supply and Ventilation | 12 |
| 2.10 | The Control Panel..... | 12 |
| 2.11 | Burner Lockout | 13 |
| 2.12 | Starting and Switching off the boiler | 14 |
| 2.13 | Frost protection | 14 |
| 2.14 | Maintenance..... | 15 |
| 3.0 | Introduction | |
| 3.1 | Suitability | 16 |
| 3.2 | Health and safety..... | 16 |
| 3.3 | Location | 16 |
| 4.0 | Installation | |
| 4.1 | Standards and Regulations | 17 |
| 4.2 | The Heating System | 17 |
| 4.3 | Domestic Hot Water System. (Combi models) | 17 |
| 4.4 | Electrical Connection | 17 |
| 4.5 | Air for Combustion and Ventilation | 18 |
| 4.6 | The Immersion Heater. (Plus models) | 19 |
| 5.0 | Sealed Systems | |
| 5.1 | System Regulations..... | 20 |
| 5.2 | Boiler models | 20 |
| 5.3 | Heating and hot water systems..... | 20 |
| 5.4 | Sealed Primary Systems | 20 |
| 5.5 | Expansion Vessel Sizing | 21 |
| 5.6 | Discharge Pipe and Safety Relief | 21 |
| 5.7 | System Filling and Commissioning | 21 |
| 6.0 | Oil Storage and Supply | |
| 6.1 | Regulations..... | 22 |
| 6.2 | Fuels | 22 |
| 6.3 | Storage Tanks and Locations..... | 23 |
| 6.4 | Installation Diagrams | 24 |
| 7.0 | Flues | |
| 7.1 | Conventional..... | 25 |
| 7.2 | Balanced | 26 |
| 7.3 | Balanced Flue clearances..... | 27-28 |
| 7.4 | Flue Assembly..... | 29-32 |
| | ERP Directive..... | 33-35 |
| 8.0 | Condensate Drain | 36-37 |
| 9.0 | Commissioning / Servicing and Maintenance | 38-39 |
| 10.0 | Fault Finding | |
| 10.1 | Boiler Fault Finding table | 40-43 |
| 11.0 | Technical Specification | 44-45 |
| 12.0 | Boiler Spares | 46 |
| 13.0 | Control Wire Diagrams | 47-51 |
| 15.0 | Installation/ Commissioning / Service & guarantee Details | 52-55 |

1.1 COSHH Regulations 1988

This information is for installers and service engineers, as required by the consumer protection act 1987 and the health and safety at work act 1974.

Every reasonable care has been taken to see that this product has been developed and built to meet these safety requirements, when installed in the manner intended.

It is the responsibility of those working on this appliance to ensure that all necessary personal protection is used to safeguard against parts and substances that may be considered hazardous to health and safety, some of which may be listed below.

Kerosene and Gas Oil (Mineral Oils) Skin Care

- Avoid as far as possible any skin contact with mineral oils
- The lighter fractions of these oils remove the protective grease normally present in the surface of the skin. This can make the skin liable to crack, and prone to damage.
- Prolonged exposure may lead to the development of warty swellings or sores. Skin rashes (Oil acne) may occur on any part of the body where there is mineral oil contact with the skin. Always wash your hands before going to the toilet.
- Do not delay in seeking medical attention if you suspect any problem.
- Before working on appliance: use suitable lanolin based creams that may give some protection against the affects of mineral oil and assist cleaning of skin. Re-apply before work is resumed after each break.

Ingestion

- Under no circumstances should mineral oils be taken internally.
- Never ingest any mineral oils.
- Never siphon by mouth.
- Never breathe any mineral oil vapours and do not fire the burner in a manner where unburnt vapours can be discharged into any work area or kitchen.

First Aid

- If mineral oil is accidentally swallowed, seek immediate medical attention and do not induce vomiting.
- If mineral oil is splashed into eyes, wash out with running water for at least 10 minutes and seek immediate medical attention.

Insulation and Rope Seals;

Glass Rope, Mineral Wool, Glass Fibre and Ceramic Insulation.

- The dust and fibres of these materials may be harmful if inhaled. Suppress any dust observed when removing fired parts by spraying with water. Safety wrap in a sealed plastic bag. Remove from the site and dispose of, in a permitted way.
- New parts should only be used as supplied and not be cut or machined. If it's necessary to cut or drill, a facemask should be worn and the cutting carefully disposed of as above.

Glue, Paint and Sealant

- These materials present no known hazard, when appliance is used for purposed intended.

1.2 In The Event of Fuel Spillage

- Stop/switch off all electrical and other ignition risks.
- Isolate the leak.
- Ventilate the area.
- Smother the spillage using sand, soil or other suitable absorbing material, but not cement.
- Avoid oil contact with combustible materials. Prevent spilt fuel from entering drains or watercourses. If it does, warn the Environment Agency, Water suppliers and Fire Service.

Handling

The products are extremely heavy, and a risk assessment, and plan of action, should be made at each site, prior to the appliance arriving.

1.3 Operation.

This appliance is not intended for the use by persons (including children) with reduced physical, sensory or mental capabilities, or lack of experience and knowledge, unless they have been given supervision or instruction concerning use of the appliance by a person responsible for their safety. Children should be supervised to ensure that they do not play with the appliance

2.1 Introduction

We are confident that our company produce the biggest range of domestic oil fired boilers manufactured in the U.K. Mistral have been manufacturing boilers for than a quarter of a century and been making condensing boilers for a number of years. Our extensive experience in condensing technology has enabled us to produce a new generation of high efficiency condensing boilers. Our unique Y shaped inner waterway allows us to achieve much greater heat transfer and therefore efficiency, whilst at the same time reducing the resistance in the boiler most commonly found with traditional condensing boilers which have no internal waterways. This enables a cleaner start up, and therefore reduces the potential for the appliances to soot up.

The main heat exchanger is made from mild steel 5 mm inner, 3 mm outer and the condensing unit is made from 316 grade stainless steel.

This high specification has been achieved through extensive research and testing to ensure our products achieve the highest quality.

2.2 Product descriptions.

Models:-

Standard KUT/BH/1-7 50/240,000 BTU'S (15-70KW)

These appliances are suitable for open vent and sealed system application.

Sealed System CS1-450/140,000 BTU'S (15-41KW)

Incorporates expansion vessel, pressure relief valve, filling loop & circulating pump as standard.

Combination CC1-4 50/140,000 BTU'S (15-41KW)

Provides for heating and hot water within one unit, priority hot water system. Includes expansion vessel, pressure relief valve and circulating pump as standard, flow rates 17.5 –20 litres @ 35°C rise and a draw off between 130 – 500 litres.

Mega Combination CMC5-7 140/240,000 BTU'S (41-70KW)

Our unique Mega Combi is used when requirement is for higher flow rates and better draw off. Flow rates from 27-35 litres @ 40 °C rise and a draw off up to 600 litres .Draw off is affected by output and flow rates.

Combination Plus (7 day, two channel programmer supplied)

Our unique product on this model is the inclusion of an immersion heater, which can either be used as a backup for hot water, or indeed used to achieve hot water if there is any issue with the burner, or lack of fuel to the appliance. Please note immersion only heats water.

Hot water performance will not be the same as when boiler is operated utilising burner.

Outdoors

Are available for all models and are particularly useful when internal space is at a premium, or you simply do not want the unit indoors.

2.3 Pre install procedures and quick reference tips.

Thank you for buying a Mistral product.

Please note the following points of added information for your attention. Non-Condensing / Condensing boilers

1. Please remove outer packaging and inspect panels for any defects prior to installation.
2. Please read the manual fully before installing the appliance.
3. The products are extremely heavy, and a risk assessment, and plan of action, should be made at each site, prior to the appliance arriving.
4. The appliance is likely to be fixed to the pallet for extra security when shipping. Normally, one screw each side of the burner, through the base.
5. Boiler should be placed on a flat level surface.
6. If the boiler is to be fitted under a work surface, this has to be removable for ease of access for servicing or maintenance work.
7. All our Y section units can be ordered as condensing or non-condensing. Prior to filling system, please check all joints are tight as they may vibrate in transit.
8. Before firing the burner, remove main boiler inspection door, and condensing unit door to ensure baffles have not moved in transit. They should be pushed back level and flush to each other. Failure to do so may affect efficiency, combustion and performance. The condensing baffles must be vertical as you look at the door. Failure to do this may affect efficiency and combustion. When replacing the door, please tighten the bolts to ensure good seal. Only a suitably qualified person should fire / set- up burner.
9. Programmer or link wires must be fitted on all combi's to operate. Will not operate with -out.

Note: Identify the following items from the drawing provided (pages 9-10)

9. Non-Condensing;

- a. Flow and return – Fig. 1
- b. Flow and return sockets are as follows;
 - 15/41 kw. = 1 BSP
 - 41/70 kw. = 1 1/4 BSP
- c. A spacer is also needed to take up the distance between the top of the exchanger and the exit for the balanced flue. For a conventional flue, a flue adapter will need to be ordered.
- d. A4 port outlet exchanger may be ordered as a special. Fig.1

10. Condensing

Condensing, Standard boilers. (see page 39/40 for assembly breakdown).

- a. Flow and return – Fig. 2
- b. Flow and return sockets are as follows;
 - 15/26 kw. = 22mm. Dia Flow + Return
 - 26/41 kw. = 28mm. Dia Flow + 22mm Return
 - 41/70 kw. = 28mm. Dia Flow + Return
- c. Condensate drain pipe – 22mm. at the rear of the unit, which allows for left exit from boiler to drain.
- d. Take note of all stats relevant to the boiler, and ensure they are in the correct pocket.

Note: Standard boiler – 1 / heating stat, 2/ hi limit stat (Fig.3 page 10)

- 11. A condensing trap is supplied to be fitted on the system – please ensure this is filled with water and that the pipe work slopes down to drain.
- 12. An isolating valve must be fitted to the oil line, inside the casing. Isolating ball valves must also be fitted on the flow and return pipes, plus the mains water in - pipe on a Combi, just prior to exiting the boiler casing, to make servicing or replacement of parts easier to undertake.

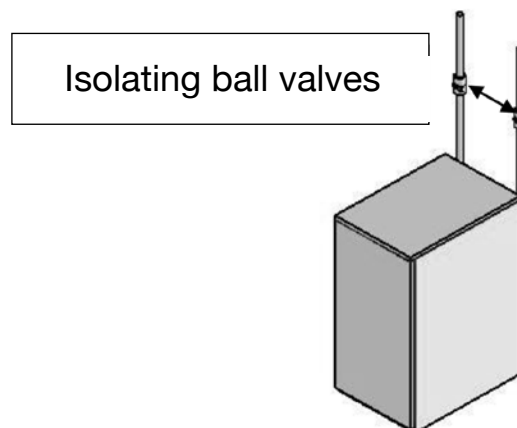

13. Make sure the correct amount of inhibitor is used when filling the system, and checked annually.
14. Frost stats should be fitted to all boilers, where there is a risk of low temperatures.
15. Condensing Combi;
 - a. Flow and return – Fig. 4
 - b. Flow and return sockets are as follows;
 - 15/26 kw. = 22mm. Dia Flow + Return
 - 26/41 kw. = 28mm. Dia Flow + 22mm Return
 - 41/70 kw. = 28mm. Dia Flow + Return
 - c. Condensate drain pipes as above.
 - d. Take note of all stats relevant to the boiler, and ensure they are in the correct pocket.
1/ heating stat, 2/ hi limit stat, 3/ pump overrun stat, 4/ hot water stat (see Fig. 3, page 10)
 - e. Check the pipework position, and direction of flow. Please ensure that when making up the flow pipe from the diverter valve, that you avoid blocking any parts of the boiler from being removed at a later stage. Fig. 5
 - f. Check arrow is pointing in the correct flow direction on the pump. Fig. 8
 - g. Check flow switch is fitted in an aligned position to the pipe, and also that the arrow is pointing in the direction of the flow. Fig. 6
 - h. Important – Hot water – the dial indicator for this should be set for position 1, unless there is a requirement for the water to be hotter. The boiler produces water at a high temperature to help against bacteria in the pipes, or overcome an extended run of pipe to the tap, and also to give the best overall performance achievable for a small store, in terms of flow rate at a given rise of temperature.
There will also be a difference to the incoming water temperature between the summer and winter, which will have an effect on the tap temperature.
If you feel that the temperature at the tap, is higher than you would like, we suggest you consider fitting either a mixer valve which can be manually operated or a thermostatic valve, which will give a more consistent result. These can be fitted either at individual taps, or alternatively, anywhere from the boiler onwards, if you would like all the water temperatures reduced.
If a mixer or thermostatic valve is fitted it may be necessary to fit a pipe thermostat to the boiler.
 - i. The expansion vessel supplied with the unit is specifically to protect the boiler, and additional vessels may be required depending on the size of the system being fitted.
Water content = 15 / 41 kw Combi = exch = store = 20 + 30 = app. 50 litres
Water content = 41 / 70 kw Combi = exch = store = 25 + 95 = app. 120 litres
16. The combi boilers are not designed for 4 port operation.
17. Non-Condensing Kuts will come as 2 port or 4 port, we recommend you always specify on the order to confirm. Blanking plugs will be supplied free issue.
18. All outdoor models should be resealed around all pipes / wires to ensure no water ingress.
- 19. Condensing Mega Combi**
 - a. For ease of transit, and on site mobility, the Mega is in 2 separate cased parts. The majority of the combi information available above is also relevant to the Mega Combi.
 - b. This unit will require a certain amount of fabrication to build on site, and although the pipework / pump / diverter valve fittings are supplied, they are not fitted, due to excessive strain on the unit during shipping.
 - c. When ready to fit together, we suggest the base fixings shown, (Fig 7) are loosened, and the pipework is assembled in the correct position as a mock up.
The heat store and the exchanger may have to be slightly adjusted to ensure everything fits together. When you are satisfied that the unit is assembled correctly, tighten all nuts down, and make pipework good. See Fig 7 / 8.
20. For all combi's – we recommend using a 7 day 2 channel programmer which can be supplied by Mistral. Although the wires can be linked for the hot water to run continuous, this is not recommended.
To ensure maximum efficiency of the boiler full programmable controls are recommended. Mistral can supply a 7 day 2 channel programmer to give full control of heating and water.
21. Please Note if setting up Blue Flame – Low Nox burner refer to burner manual for information.
22. We hope that this list has been of some help, however, if you need any more assistance please feel free to call Mistral Energy Products Ltd, and our technical department will try to resolve any problem you may encounter.

Mistral Boiler

SPECIFICATIONS

HIGH EFFICIENCY CONDENSING BOILERS

| | | BOILER SIZE | | | | | | | |
|-------------------------|-------------|---|-----------------------------|------------------------------|-------------------------------|-------------------------------|------------------------------|-------------------------------|------------|
| | | 15 – 20 KW 50-70,000 BTU | 20 – 26 KW 70-90,000 BTU | 26 – 35 KW 90-120,000 BTU | 35 – 41 KW 120-140,000 BTU | 41 – 50 KW 140-170,000 BTU | 50 – 58 KW 170-200,00 BTU | 58 – 70 KW 200-240,000 BTU | |
| | | MODEL NUMBER | | | | | | | |
| BOILER TYPE | PREFIX CODE | SEDBUK RATING | 1 | 2 | 3 | 4 | 5 | 6 | 7 |
| KITCHEN UTILITY | CKUT | A | | | | | | | |
| BOILER HOUSE | CBH | A | | H865mm x W410mm x D600mm | | WGT 140 kg | | | WGT 245 kg |
| SYSTEM | CS | A | | | | WGT 140 kg | | | WGT 245 kg |
| COMBI STD | CC | A | | | | WGT 145 kg | | | |
| COMBI PLUS | CC-PLUS | A | | H865mm x W600mm x D600mm | | WGT 190 kg | | | |
| OUTDOOR UTILITY | COD | A | | | | WGT 195kg | | | |
| OUTDOOR SYSTEM | COD-SS | A | | H895mm x W480mm x D680mm | | WGT 135 kg | H1245mm x W550mm x D810mm | | WGT 245 kg |
| OUTDOOR COMBI STD | COD-C | A | | H895mm x W480mm x D680mm | | WGT 140 kg | | | |
| OUTDOOR COMBI PLUS | COD-C-PLUS | A | | H895mm x W635mm x D680mm | | WGT 195 kg | | | |
| MEGA COMBI STD | CMC | A | | | | WGT 200 kg | | | |
| MEGA COMBI PLUS | CMC-PLUS | A | | | | | H1230mm x W1100mm x D755mm | | WGT 390 kg |
| OUTDOOR MEGA COMBI STD | COD-MC | A | | | | | Shipped In 2 Parts | | WGT 395 kg |
| OUTDOOR MEGA COMBI PLUS | COD-MC-PLUS | A | | | | | H1245mm x W1100mm x D810mm | | WGT 395 kg |
| | | | | | | | Shipped In 3 Parts | | WGT 400 kg |
| Notes:- | | <ol style="list-style-type: none"> 1. E.G. = CKUT1 = Kitchen Utility 15/20kw (50-70,000btu), Sedbuk A Rated, H865mm x W410mm x D600mm, WGT 140kg. 2. E.G. = COD6 = Outdoor Utility 50/58kw (170-200,000btu), Sedbuk A Rated, H1245mm x W550mm x D775mm, WGT 245kg. 3. For ease of handling Mega Combi's are shipped in 2 parts. Outdoor Mega Combi's are shipped in 3 parts. 4. All units are approx dry weights of boilers. Dimensions may vary. 5. Safety – Due to the excessive weight, a risk assessment is advised before purchase. | | | | | | | |

Mistral Boiler

SPECIFICATIONS

STANDARD EFFICIENCY BOILERS

| BOILER TYPE | PREFIX CODE | SEDBUK RATING | BOILER SIZE | | | | | | | | | | | | | |
|-------------------------|-------------|--|-----------------------------|-----------------------------|------------------------------|-------------------------------|-------------------------------|------------------------------|-------------------------------|---|--|--|--|--|--|--|
| | | | 15 – 20 KW 50-70,000 BTU | 20 – 26 KW 70-90,000 BTU | 26 – 35 KW 90-120,000 BTU | 35 – 41 KW 120-140,000 BTU | 41 – 50 KW 140-170,000 BTU | 50 – 58 KW 170-200,00 BTU | 58 – 70 KW 200-240,000 BTU | | | | | | | |
| | | | MODEL NUMBER | 1 | 2 | 3 | 4 | 5 | 6 | 7 | | | | | | |
| KITCHEN UTILITY | KUT | B | | | | | | | | | | | | | | |
| BOILER HOUSE | BH | B | H865mm x W410mm x D600mm | WGT 125 kg | | | | | | | | | | | | |
| | | | | WGT 125 kg | | | | | | | | | | | | |
| | | | | WGT 130 kg | | | | | | | | | | | | |
| SYSTEM | S | B | | | | | | | | | | | | | | |
| COMBI STD | C | B | H865mm x W600mm x D600mm | WGT 175 kg | | | | | | | | | | | | |
| COMBI PLUS | C-PLUS | B | | WGT 180 kg | | | | | | | | | | | | |
| OUTDOOR UTILITY | OD | B | H895mm x W480mm x D680mm | WGT 120 kg | | | | | | | | | | | | |
| OUTDOOR SYSTEM | OD-SS | B | | WGT 125 kg | | | | | | | | | | | | |
| OUTDOOR COMBI STD | OD-C | B | H895mm x W635mm x D680mm | WGT 180 kg | | | | | | | | | | | | |
| OUTDOOR COMBI PLUS | OD-C-PLUS | B | | WGT 185 kg | | | | | | | | | | | | |
| MEGA COMBI STD | MC | B | | | | | | | | | | | | | | |
| MEGA COMBI PLUS | MC-PLUS | B | | | | | | | | | | | | | | |
| OUTDOOR MEGA COMBI STD | OD-MC | B | | | | | | | | | | | | | | |
| OUTDOOR MEGA COMBI PLUS | OD-MC-PLUS | B | | | | | | | | | | | | | | |
| Notes:- | 1. | E.G. = KUT1 = Kitchen Utility 15/20kw (50-70,000btu), Sedbuk B Rated, H865mm x W410mm x D600mm, WGT 125kg. | | | | | | | | | | | | | | |
| | 2. | E.G. = OD6 = Outdoor Utility 50/58kw (170-200,000btu), Sedbuk B Rated, H1245mm x W550mm x D810mm, WGT 230kg. | | | | | | | | | | | | | | |
| | 3. | For ease of handling Mega Combi's are shipped in 2 parts. Outdoor Mega Combi's are shipped in 3 parts. | | | | | | | | | | | | | | |
| | 4. | All units are approx dry weights of boilers. Dimensions may vary. | | | | | | | | | | | | | | |
| | 5. | Safety – Due to the excessive weight, a risk assessment is advised before purchase. | | | | | | | | | | | | | | |

Fig :- 1

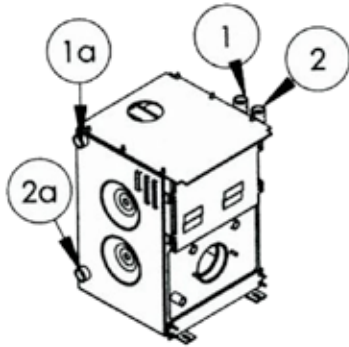

**NON-CONDENSING
PIPE POSITIONS**

STANDARD

- 1, FLOW
- 2, RETURN

4 PORT OUTLET

- 1a, FLOW
- 2a, RETURN

4- port is optional - not standard

Fig :- 4

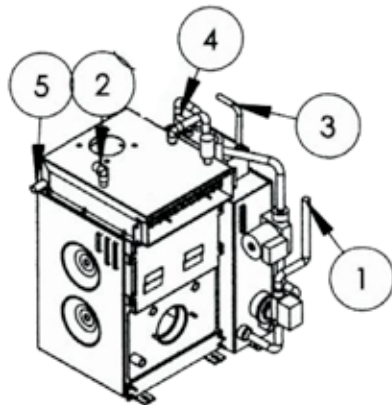

PIPE POSITIONS

- 1, FLOW
- 2, RETURN
- 3, COLD FEED IN
- 4, HOT WATER OUT
- 5 CONDENSING DRAIN

Fig :- 2

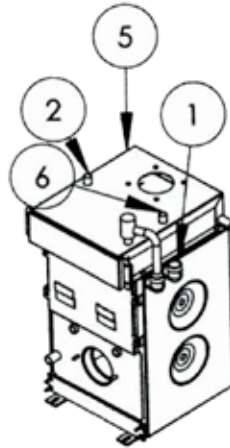

PIPE POSITIONS

- 1, FLOW
- 2, RETURN
- 5, CONDENSING DRAINS
- 6, CAPPED OFF RETURN

Fig :- 3

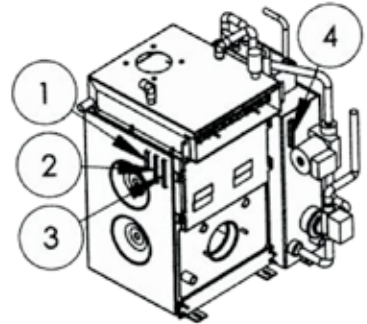

STAT POSITIONS

HEAT EXCHANGER

- 1, HEATING
- 2, HI LIMIT
- 3, PUMP OVER RUN

HEAT STORE

- 4, HOT WATER

Fig :- 5

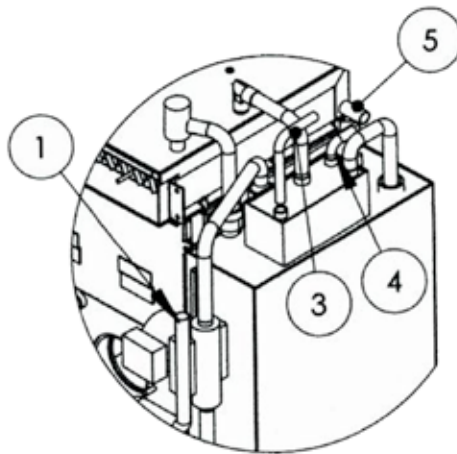

PIPE 1 POSITION
SHOULD BE MADE
TO FIT ON THE
RIGHT SIDE OF PUMP.
TO GIVE FULL ACCESS
TO FRONT DOOR

Fig :- 6

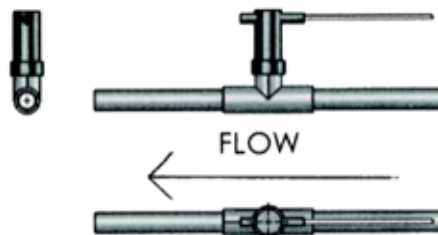

Fig :- 7

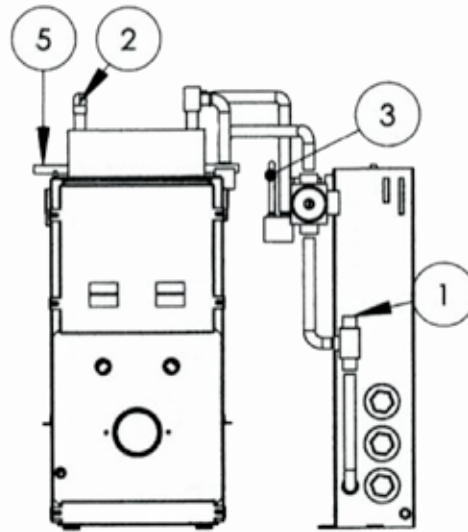
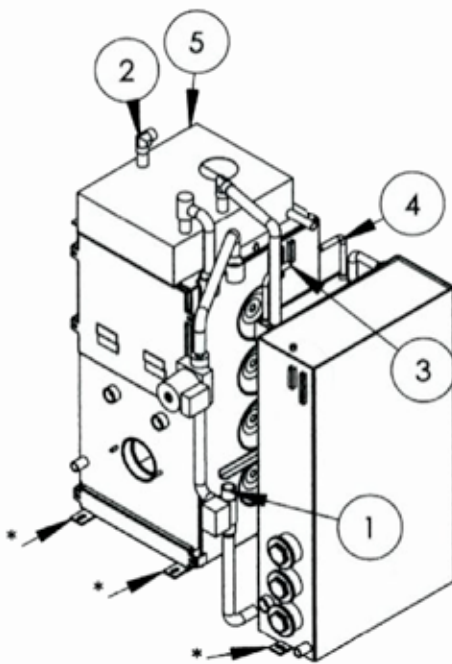
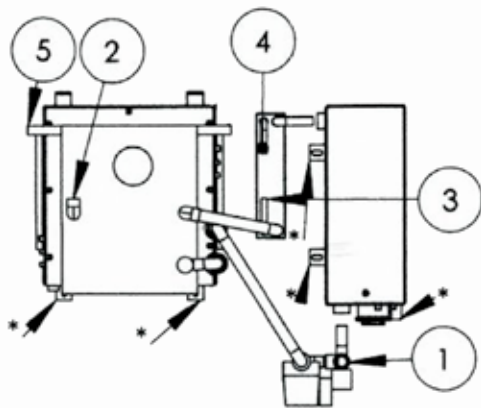

Fig :- 8



PIPE POSITIONS

- 1, FLOW
- 2, RETURN
- 3, COLD FEED IN
- 4, HOT WATER OUT
- 5 CONDENSING DRAIN

* FIXING LUGS
 EXCHANGER =2 OFF
 STORE =3 OFF

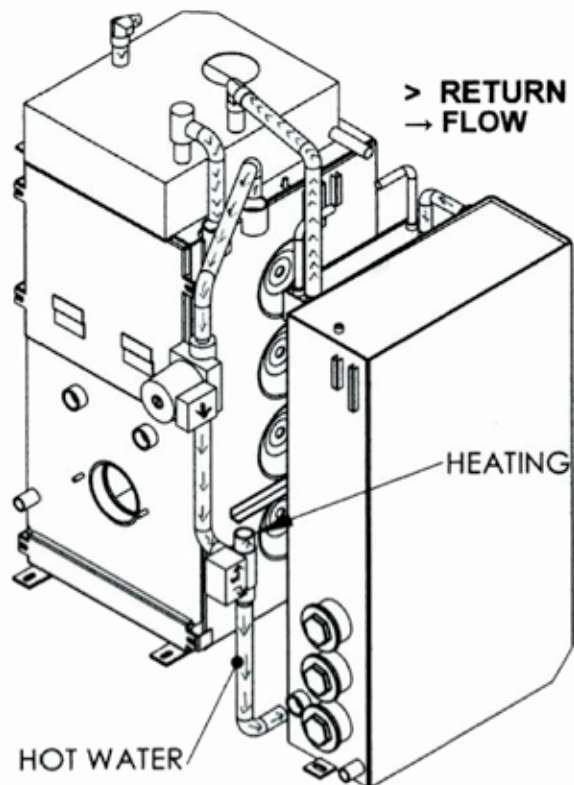

2.5 Safety. Please refer to figure 1.0 Health and Safety on page4.

2.6 **Oil Supply.**

Fuels. This range of boilers is designed to burn on BS 2869 Part2, Class C2 28 Sec Kerosene.

2.7 **Electrical Connection.** The electrical connection and cable should be installed by a suitable qualified person in accordance to the current wiring regulations. Your boiler should be connected to the electrical supply via a fused isolator (5 amp fuse), located on an adjacent wall, and on Mistral Combi Plus immersion heater version should be connected directly to your consumer unit (20 amp ELCB circuit), via a double pole isolator located on adjacent wall. If the supply cord is damaged it must be replaced by a service agent or similar qualified person in order to avoid a hazard.

Always Isolate Electrical Supply Before Internal Cover is removed.

2.8 **Useful information.**

Date of Installation Boiler Model

Boiler Serial Number

Oil Type to BS2869 Class C2 28 Sec Kerosene

Oil Tank Capacity:

2.9 **Air Supply and Ventilation**

The boiler can be fitted with the following flue type:

Conventional Flue

This type requires a permanently open air vent; which must not be closed off, to supply air combustion and to allow the flue system to work.

Conventional flue system must be suitable to be used on an oil fired condensing boiler. Please contact flue supplier or manufacturer.

Balanced Flue

This type does not require a permanently open air vent supply, however, ventilation may be required if appliance is enclosed within a cupboard or small compartment to prevent the appliance from over heating.

Reference may have changed since publication. It is the responsibility of the installer to check current regulation before installing

WARNING! PLEASE ENSURE COMBUSTION AIR VENTS AND FLUE WAYS ARE NOT OBSTRUCTED OR CLOSED.

2.10 **The Control Panel CKUT, CBH, CS, COD and CODSS (non Combi)**

This is provided with 1 to 6 on the face of the control thermostat. Should you wish to turn the appliance off, turn the control thermostat to the off position.

Summer/Winter settings. You are advised not to operate your appliance below a setting of 55°C which relates to number 3 on your control thermostat.

Summer Settings: For domestic hot water select settings 3, 4 and 5 (55/65°C) on your control thermostat.

Winter Settings: For domestic hot water and central heating select settings 5-6 (68/80°C) on your control thermostat.

The Control Panel CC and CODC, Plus and Standard models.

Is provided with the following features:

Control Stat



1. Central heating (CH) control thermostat.
2. Hotwater (DHW) control thermostat.
3. Selector switch: BR / OFF / IM as positions I/O/II
4. Boiler high limit (HL) thermostat, reset button
5. Green power on neon.
6. Clear boiler on neon.
7. Amber Immersion Heater on neon. (PLUS)
8. Red boiler high limit in dicator neon.
9. Fuse holder for boiler controls circuit (5 amp).
10. Sealed system pressure gauge.
11. Dual channel programmer. (optional extra on standard models)

2.10.1 **The central heating thermostat** has a dial knob for boiler temperature control in the range 55/82°C. This is shown on the knob as number 1 to 6 and should you wish to turn the boiler off for a short period, turn the knob to the OFF position.

Settings. You are advised not to operate your boiler below 55°C which relates to setting number 3 on your control knob.

For normal heating, select between number 4 and 5 (70/76°C) on your control knob. In severe weather conditions it may be necessary to select number 6 (82°C) on your control knob.

2.10.2 **The hot water control thermostat** This range is from 30-80°C and has numbers 1 to 6. The use of this control allows you to limit the stored water temperature, select the number in the range (1 = 30°C to 6 = 80°C), that best suits your needs.

Note! water temperature will be less in colder periods due to much colder mains water passing through the heat exchanger. You may have to adjust/decrease the flow at source (tap) to increase water temperature.

However as the hot water production from this boiler is highly efficient you find under certain circumstances of low flow rate, that the water temperature at the point of use may be for a short period too high. Should this prove to be a nuisance, your installer, will be able to advise the uses of an appropriate temperature mixer valve.

2.10.3 **The boiler selector switch.** Controls either the boiler On or immersion heater On, (immersion heater only applicable to plus models) with an intermediate off position and is indicated on the switch as: I/ O /II. The neon indicators show the selection. Switching the selector to O and II also removes the power to the programmer.

2.10.4 **High Limit Thermostat**

Under the small black finger tight cap located to the side of the thermostat is housed the reset button for the high limit thermostat. Should it be necessary to reset, wait until the appliance has sufficiently cooled down to allow for the thermostat to reset. Should this persist, contact your installer or service engineer.

2.10.5 **Dual Channel Programmer. (Combi models)**

Provides full control over heating and hot water.

Please note that programmer is an optional extra on the standard model combi.

2.10.6 **Control panel pressure gauge (applicable system & combi models)**

For sealed systems, the panel incorporates a pressure gauge On the front face of which is a red arrow pointer, that should be set to minimum system pressure. The indicator gauge pressure should not exceed 2.0 bar 200 KPA when the boiler is hot, nor less than 0.5 bar 50 KPA. It is important to refer pressures outside these ranges to your installer.

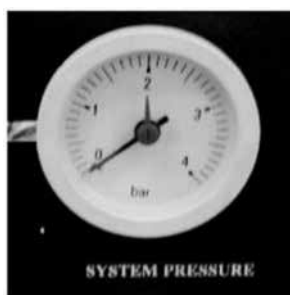

Pressure

2.11 **Burner Lockout.** The burner has an independent control system (Burner Control Box). This incorporates a flame detector (Photocell) which detects the presence of the burner flame. In the event of a flame failure, the burner control box activates a second re-ignition sequence. Should the photocell not detect a flame presence within 15 seconds the burner will go to lockout, and a display illuminates a red button on the burner control box.

Reset Button →



Riello RDB Burner

If MHG burner (blue flame - Low Nox also see burner manual)

Continued LOCKOUT is a result of a fault in the operation of the boiler and can be attributed to the following examples:

- An interruption of fuel supply.
- Electrical supply fault e.g. Extreme low voltage.
- Failure of a burner component.
- Flue obstruction.
- Obstruction of combustion air ventilation.
- Burner combustion not being correct.

Warning! Only attempt to restart burner twice, if the appliance fails to start contact your installer or service engineer.

2.12 Starting and switching off the appliances

Following the points outlined in figure 2.7 (summer/winter settings) and 2.8 (failure to start burner lockout)

The combi may be used for heating only or hot water only. Selection is by use of a programmer:

- Switch on the power supply.
- Switch the selector to I (BR).
- Set thermostat to desired setting and see that other controls such as room thermostat and programmer are calling for heat as required.
- Start-up is fully automatic once the desired settings are made.

(Non Combi) Set the control thermostat to the desired setting and check other controls are calling for heat.

To switch the boiler off.

- **Short term:**
 1. Turn the appliance thermostat to off, or switch internal / external controls to off position.
- **Long term:**
 1. Switch off the appliance power supply.
 2. Shut off oil supply to the appliances.
 3. If the dwelling is being left un-attended for an extended period and there is a risk of freezing consider either draining down system or adding a heating system anti freeze to the system.

2.10 The immersion heater. (Plus models only)

The unique immersion heater is switched on at the selector position II. This removes the power to the immersion, but leaves the internal circulating pump and diverter valve junction in the hot water mode. The immersion heater allows for sufficient hot water in the event of loss of oil supply. You are advised not to wait for the oil to run dry as it can cause a break down. The immersion heater also contains a thermostat which operates in the range 40-80°C

2.13. Frost Protection.

During winter absences away from home, you may lower the room thermostat and boiler control thermostat to 1 or reduce the time clock/programmer settings or preferably if you have a programmable room stat, set it to the frost setting.

If the appliance is located in an outhouse or garage and there is a possibility of freezing, a frost thermostat should be considered.

Outdoor Models Frost Protection (Non combi)

It is strongly recommended that a pipe thermostat be wired in series to ensure that overheating of

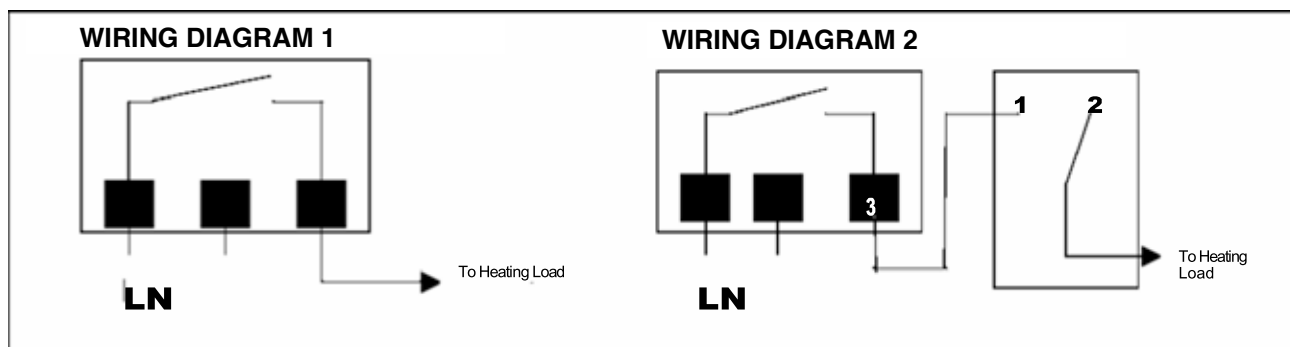

property does not occur. The pipe thermostat should be sited on the heating return pipe, wired as shown in wiring diagram 2, below and set to 5°C (depending on system and location).

The frost thermostat must be wired to override all other time and temperature controls, and preferably to switch on the heating circuit, rather than the hot water circuit.

When a frost thermostat is installed on a central heating system, the fused spur should only be switched off for servicing and maintenance. If the appliance is to be switched off for any reason e.g. holiday, then switching must only be carried out at the programmer or time clock.

Please note for wiring of frost stat on combi model refer to combi wiring diagram at the back of the manual.

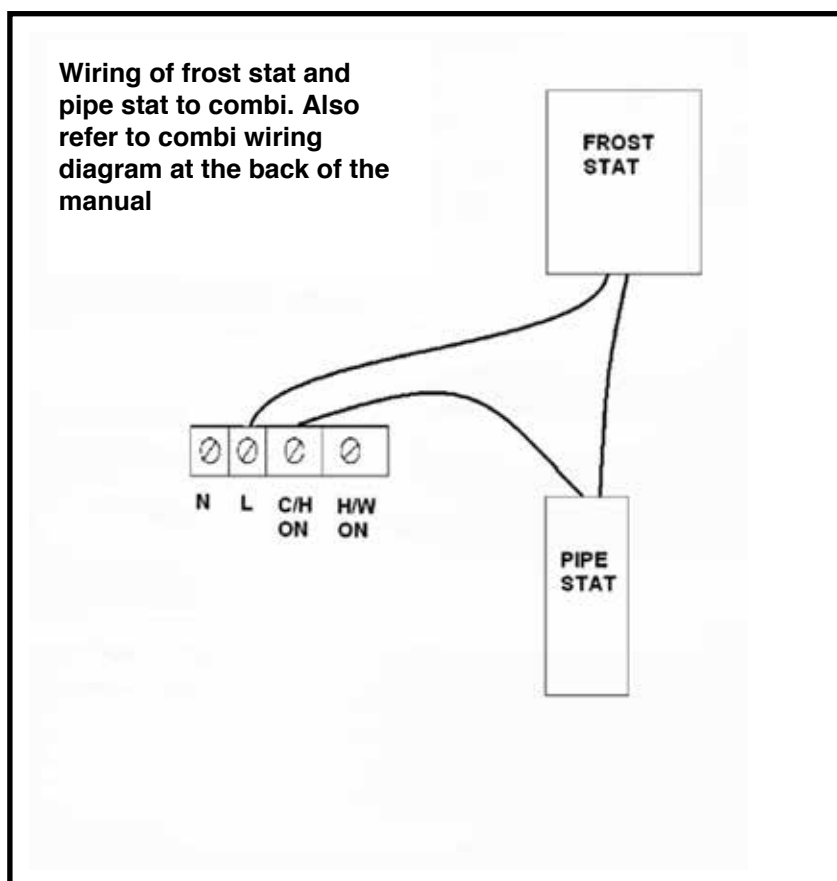

2.14 Maintenance and Servicing

To ensure reliable and efficient operation of your appliance, it is essential, that once the appliance is installed, it is commissioned and subsequently serviced within a maximum 12 months by an OFTEC registered or suitably qualified engineer. Failure to do so will invalidate your warranty, but not your statutory rights. It is the responsibility of the installer to ensure that the boiler is commissioned. To clean the outside casing, wipe with a damp cloth and avoid using abrasive cleaning materials.

INTRODUCTION

3.1 Suitability.

Mistral oil fired boilers are fully automatic, horizontally fired pressure jet boilers, complying with European directives for boiler efficiency, low voltage and EMC and are designed for use as follows:

1. Indirect, open - vented central heating and hot water systems.
2. Indirect, un - vented sealed central heating and hot water system.
3. For maximum system operating pressure up to 3 bar 300 KPA.
4. For connection to approved conventional or factory made chimney.
5. For use with Mistral own balanced flue system
6. As a replacement for existing boilers or as part of a new installation.

3.2 Health and Safety.

Please refer to the COSHH information printed on the inside cover of the manual.

- In the interest of safety reliability and efficiency the appliance should be installed and commissioned by an OFTEC or suitably qualified engineer.
- The equipment supplied by Mistral Energy Products Ltd in the way of boiler or flue, should not be modified or used outside the scope of its suitability, unless described within this manual or through direct discussion with Mistral.
- Electrical wiring to the boiler and heating system should be undertaken by a suitably qualified electrician and comply with the last wiring regulations BS7671. No attempt should be made to modify or change the internal wiring of the boiler.

3.3 Location.

- **The Hearth**

The boiler must stand on a firm level hearth which complies with current building regulation. The base temperature of the appliance does not exceed 85°C. If the boiler is to be positioned on a hearth of combustible material, suitable protection should be placed underneath which is non combustible and impervious to oil.

- **Siting.**

The noise level of the appliance is low and so makes them ideally suitable for siting within the kitchen, the utility room or garage. As some people are more sensitive to noise than others, it is good practice to discuss the intended location beforehand.

When choosing the location for a condensing boiler special consideration must be given to the positioning of the flue terminal. Care should be taken to locate it so as to prevent either the end user or their neighbours perceiving the plume to be a nuisance. It should be noted that the normal statutory clearances required around low level flue terminals may not be sufficient to cope with plume dispersal from a condensing boiler.

The following points should be considered:

1. Plumes can extend out horizontally and can also drift out to the sides and above the terminal. Care needs to be taken therefore to avoid the plume reaching adjacent surfaces, particularly windows and neighbours dwellings.
2. Flue terminals need to be located where air can pass freely across them to disperse vapour.
3. The effect of the moisture generated must be considered in relation to possible corrosion of metal parts it might reach and to the possible formation of ice on pathways in freezing conditions.
4. Keep flue terminals a minimum of 1 m (horizontally) from openings in the building.
5. Do not install flue terminals directly below a window. (see diagram page 27/28)
6. Do not install flue terminals next to a door. (see diagram page 27/28)
7. Do not install flue terminals within 1 m of ventilated soffits or eaves. (see diagram page 27/28)
8. Keep flue terminals at least 1 m away from a surface or boundary facing a terminal. (see diagram page 27/28)

Avoidance of any potential nuisance can normally be achieved by utilising one of the many differing flue options available.

For condensing boilers, the same requirements apply for installation with regard to cleaning and flushing and providing inhibitors, as are followed for any other boiler

4.1. Standards and Regulations.

The installation of this boiler must comply with the latest edition of the following standards:

| | |
|--|---|
| BS 799:5 | Specification for Oil Storage Tanks. |
| BS 4543 | Pt 1 & 3 Factory made Chimneys. |
| BS 5410 | Pt 1 Oil Installations under 44kW. |
| BS-EN – 12828 12831 2003 | Forced Circulation Hot Water Central Heating Systems for Domestic Premises. |
| BS 7074 | Pt 1 & 7 Sealed System Components and Codes of Practice. |
| BS 7593 | Code of Practice for Treatment of Central Heating Water in DHWS. |
| BS 7671 | Electrical Wiring Regulations. |
| THE BUILDING REGULATIONS | |
| Part J & L | England and Wales. |
| Part F | Section 111 Scotland. |
| Part L | Northern Ireland. |
| The Control of Pollution (Oil) Regulations | |
| BS 5955:8 | Installation, Plastic Pipes and Fittings |

Special consideration should be given for condensate removal and plume dispersal. The installation of oil firing condensing boilers is the same as for non-condensing boilers.

BS 5410: Part 11997 gives the requirements for domestic boiler and oil storage installations.

For condensing boilers the same requirements apply for installation with regard to cleaning and flushing and providing inhibitors as are followed for any other boiler.

4.2. The Heating System.

This boiler can be used for a new installation or as a replacement fitted to an existing installation.

Ensure that the system is thoroughly cleaned and flushed through prior to filling and for long term protection a suitable corrosion and scale inhibitor should be added to the primary water.

Kettling and system noises can best be avoided with the removal of swarf and residues prior to filling with clean water and the addition of a proprietary system inhibitor, before first firing, is strongly recommended.

To avoid nuisance over temperature tripping out of the boiler limit thermostat, due to reduced or no water flow through the boiler whilst the burner is firing, it is strongly advised that the control system should be wired so that the burner is switched off at the same moment as the circulating pump.

Where thermostatic radiator valves are employed, these may well cause reduced return flow to the boiler as they close down. To avoid affecting the boiler flow, it is preferable to include in the system, a by-pass loop between the flow and return, which incorporates a proprietary by-pass valve that is sensitive to the change in pressure. Before filling the system, ensure that any unused sockets have been plugged and the boiler drain down point is closed.

Garage Installations are dealt with in the OFTEC Technical advice publication TI/1 27.

4.3. Domestic Hot Water System. (Combi models)

The cold mains inlet fittings provides a 15 mm compression joint.

The water supply pressure to the boiler should be within the range of 1.0 100 KPA to 300 KPA. If pressure exceeds 3.0 bar 300 KPA fit a pressure reducing valve.

Cold Water Supply and Treatment. To minimise scale formation in the plate heat exchanger it is important to know how hard the water supply is. This hardness information is available from the local water company.

Where water hardness of over 150ppm is expected, it is recommended that water treatment is fitted. This would preferably be a water softener. There are also signal type water conditioners that are connected to electrical supply external to the boiler. Without treatment it is to be expected that the natural scale build up will with time, reduce the heat transfer efficiency of the plate heat exchanger.

4.4. Electrical Connection. (Heat only and combi standard)

The external electrical supply required is: 230V, 1 ph, 50Hz,

The supply must be fused at 5 Amps by a double pole isolation switch, with a contact separation for each pole of 3mm and with shuttered sockets. Mounted adjacent to the boiler, it must isolate all of the boiler and control system.

The supply connection to the control panel is through a removable three way plug located in the base of the control panel.

Room or frost thermostats used should be able to switch mains supply voltage and have a contact rating of at least 10 amps.

Electrical Connection. (Combi plus)

The external electrical supply required is: 230 V, 1 ph, 50Hz,

The supply to combi plus must be through a direct spur to the consumer unit and ELCB fused at 20amps. This provides for the immersion heater application, the boiler being protected by a 5 amp fuse holder on the underside of the control panel.

There should be adjacent to the boiler a suitable means of isolation, via a double pole isolation switch, with a contact separation for each pole of 3 mm and shuttered sockets. It must isolate all of the boiler and control system.

Wiring connections.

1. Supply connection to the control panel is through a removable three way plug located in the base of the control panel. There is no need to enter the control panel for supply connection. You are advised to run heat resisting cable with a cable size of 2.5 mm, this to provide for the integral pre - wired 3kW Immersion Heater within the thermal store.
2. Room thermostat / Programmerable room stat. (Combi models) the thermostat selected should be able to switch mains supply voltage and have a contract rating of at least 10 amps. The connection is to the 12 way terminal strip numbers 11 and 12 having first removed the red link.

4.5. Air for Combustion and Ventilation.

The provision of a permanent and adequate air supply is essential for the safe and efficient operation of the boiler, and must cater as follows:

- Air for combustion and to allow the flue to evacuate all the flue products.
- Air for ventilation to prevent overheating, if the boiler is installed in a confined space
Or compartment.

Air for combustion (conventional flue)

British Standard Code of Practice BS5410: pt1. Require a permanent opening from outside, into the room containing the boiler of 550mm² for each kW of boiler maximum output.

Where a stabiliser is fitted 1 100mm²/kW is required, but not if the boiler is in a ventilated compartment.

Preferably located at high level, to avoid discomfort to the occupants and any possibility of being blocked off to prevent draughts.

Air for ventilation (conventional flue)

In addition to air for combustion, British Standard requires high and low level permanently open vents, where the boiler is located in a compartment or confined space.

- Where air is taken from outside the building, high and low level vents each of 550mm² for each kW of boiler maximum output are required.
- Where air is taken from an adjoining heated space, high vent of 1100mm² and low vent of 1650mm² for each kW of boiler maximum output are required and from the same room.
- Basement installations require air for combustion to be ducted to low level.
- Restrictions Oil fired boilers must not draw air from a bedroom.
- Extract Fans With all doors windows and adjustable vents closed and the extractor on maximum setting, there must be no adverse effect on the combustion performance. Tests should be made of CO₂ and smoke with the fan on and off.

The maximum permissible rate of fan extract for a pressure jet burner is 40 litres per second.

With extraction from an adjoining room, the intervening door should be left open.

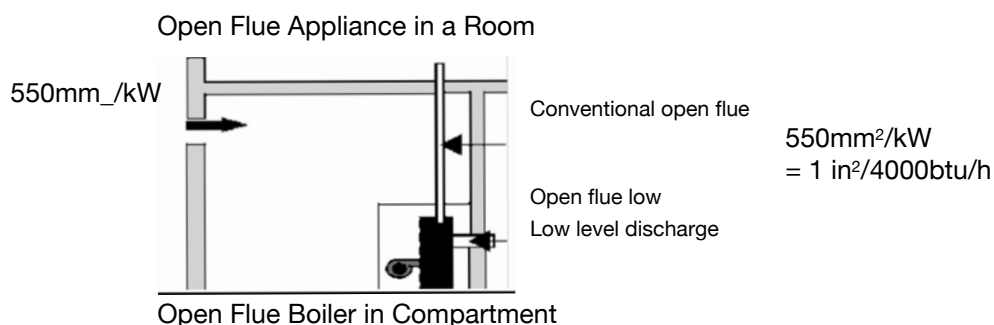

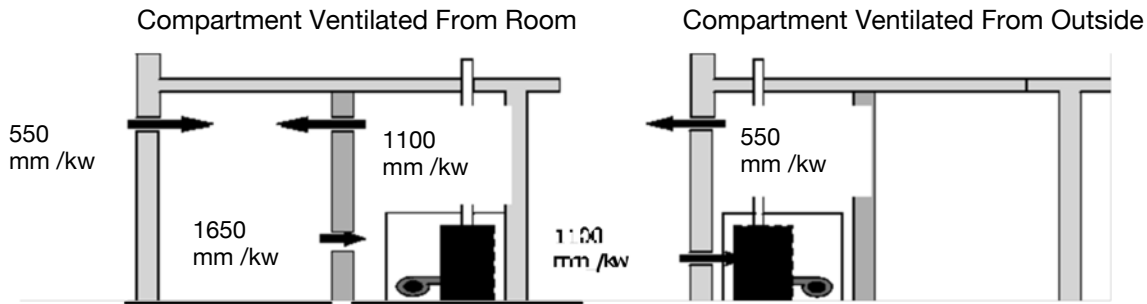

Balanced Flue Boiler in Compartment

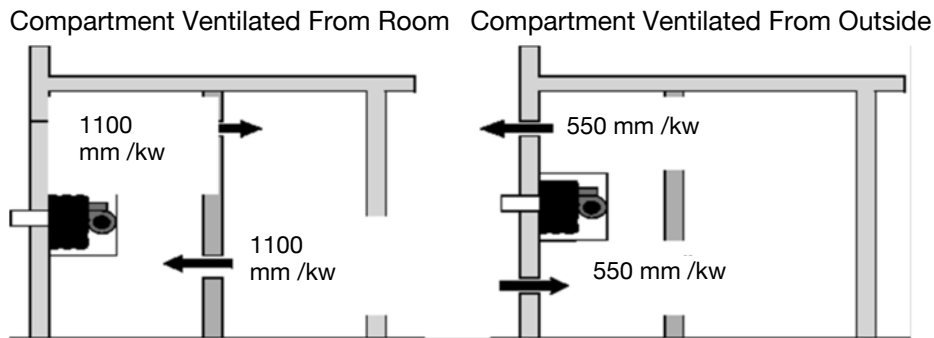

The above information supplied by OFTEC

4.6 The Immersion Heater. (Plus models)

The Immersion Heater is pre-wired to the boiler control panel and requires no further attention.

It's internal thermostat operates independently to all other boiler thermostats and is set at 65°C.

When the immersion heater is selected on the front of the control panel switch: position II, the integral circulating pump is energised. It remains in operation throughout this selection, to provide heat transfer at the plate heat exchanger.

Warning! Do not operate the immersion heater without the heating system being first, filled with water and bled of air

SEALED SYSTEMS

- 5.1. **System Regulations.** In addition to the installation standards and regulations outlined earlier in 4.1. Sealed System installations must comply with the latest edition of:
- BS 7074 pt 1. Application, selection and installation of expansion vessels and ancillary equipment for sealed systems.
 - BS 7074 pt 7. Code of practice for sealed systems.

- 5.2. **The Boilers: Models CKUT, CBH, COD** are suitable for incorporation in a sealed un-vented heating or hot water system as they are equipped with a manual reset limit thermostat. They do not however contain within their construction any of the components required for filling or water pressure safety.
- Models CC, CODC, ODCS and CS These boilers are supplied with all the necessary components for connection to a sealed un-vented heating or hot water system as follows:
 - Expansion Vessel. Pre charged at 1.0 bar 100 KPA (14.5 psi) Is suitable for a static head of up to 10.2m, measured from the highest point of the system; usually the top of the bedroom radiators, to the mid point of the vessel. For other static heads the pre-charge must be adjusted, either by lowering to 0.5 bar 50 KPA for 1.5 m, or increasing to 1.5 bar, 150 KPA for 15.3m. For this purpose a standard tyre valve is provided on the expansion vessel. Measurement is achieved using a tyre gauge, with the vessel disconnected from the system or the system empty of water. Higher pressures are made by pumping up with a conventional foot pump.

The pre-charge must not exceed 1.5 bar.

- **Pressure Relief Valve.** Factory set at 3.0 bar 300 KPA (43.5 psi.), and located on the front left hand side of the heat exchanger.
- **Circulating Pump.** Grundfos three speed variable head with heavy duty ball isolating valves. Mounted on the internal boiler flow pipework. Direct installer connection to 22mm compression.
- **Automatic Air Vent.**
- Pressure Gauge 0-4 bar 0-400 KPA. Control panel mounted and connected to the pressure relief valve tapping.
- **Filling and Make-up Loop.**
- **Limit Thermostat – Manual Reset.**

Setting at 11 0°C ±6°C. Reset button located on the front face of the control panel under the black finger tight knob. Should the boiler overheat and the limit thermostat trips it can not be reset until the boiler has cooled sufficiently. **See section 11 for spares components**

5.3. Heating and Hot Water Systems.

The CC, CODC, ODCS and CS models are specifically designed for use on sealed un -vented systems. They can however be used on an open vented system in accordance with the normal requirements applicable to this type of installation.

The boilers incorporate an in-built circulating pump.

Thermostatic radiator valves and lock shield valves must be suitable for the higher system operating pressures.

- **System Filling Point and Make-up.**
The connection point on the boiler may be capped off and an alternative location provided elsewhere on a low point of the system, if preferred. This must however be in accordance with local water undertaking regulations.

The make-up provision on the system boilers for replacement of lost water is through the filling loop. However, other means can be provided via a make-up vessel or tank. This would be mounted in a higher position than the top point of the system and connected through a non-return valve into the system. On the return side of either: the hot water cylinder or all of the radiators.

Loop must be disconnected from one of its connections when not in use.

- **Mains water Connection.** There must be no connection to the mains water supply other than through the temporary filling loop connection at the time of filling or recharging.
- **Hot Water Storage Vessel.**
This should be of the indirect coil type or a direct cylinder fitted with immersion califier which are suitable for the intended system pressure of 0.35 bar 35 KPA above the safety relief valve setting. That is 3.65 bar 365 KPA.

5.4. Sealed Primary Systems.

The pressure gauge mounted on the control panel indicates the system pressure once cold charged and during the heating cycle. It also has a red arrow pointer that is positioned to indicate the cold charge point of the system and serves as a warning to indicate loss of system water. When the boiler is fired the system pressure

- 20 The expansion vessels initial charge must not be less than the static head pressure of the system.

5.5. Expansion Vessel Selection.

Refer to the sizing table at the end of this section for the explanation on vessel sizes and system water volumes. It is important that an additional vessel is connected to the system should the hot cycle pressure exceed 2.3 bar 230 KPA.

5.6. Discharge Pipe.

Discharge from a safety relief valve must be to a safe location, one where it:

- Is visible,
- Cannot discharge over people i.e. above an entrance window, or any type of public access,
- Cannot cause damage to property, and is preferably at low level.

The discharge pipe must be at least the same size as the connection to the valve (15mm). The fall of the discharge route must be sufficient to prevent blockage through freezing.

Warning! The discharge pipe could emit boiling water

5.7. System Filling and Commissioning.

The flexible hose on the filling loop kit provides the means of initial system filling from the mains water supply and for subsequent topping up of the system.

There is, provided on the boiler, a double check valve with a shut -off ball valve located on the mains side. Both the check valve and shut -off valve are made to accept the “O-ring” sealed end connections of the flexible hose. The wing nuts do not require more than finger tightening. Disconnect one end of the hose after filling.

To fill the system:

- Connect and see that the filling hose is secure between the mains and the double check valve.
- See that all valves except the valve on the double check valve, are open and that the automatic air vent"s plastic cap is open to release air.
- Open the mains shut-off valve and gradually open the ball valve on the double check valve, until the system pressure reaches 1 - 1.5 bar 100 - 150 KPA.
- Close the filling loop valves and inspect the system for leaks, repairing as necessary.
- Vent the system at the radiators boiler and circulating pump, beginning at the lowest level.
- Check the operation of the safety relief valve by releasing the red plastic knob until a click is heard. Allowing water to vent through the discharge pipe check that the discharge is free of obstruction and allows it to flow to the drain point.

Expansion Vessel Sizing Table:

1. **The volume of the expansion vessel chosen must not be less than given in the table.**
2. **Additional expansion vessels, if needed, should be fitted as close as practicable to either the inlet or outlet of the boiler.**
3. **Generally with an initial system pressure of 0.5 bar (metres) 50 KPA, a system capacity of about 145 litres (31.5 gallons) can be accommodated with the 12 litre vessel supplied on the system models.**
4. **The air charge in the expansion vessel should not exceed 1.5 bar 150 KPA**
5. **Fill as necessary to the system design pressure. Close filling loop valves.**
6. **Remove one end of the filling loop hose from its connection.**
7. **Finally, check the operation of the manual reset thermostat by allowing the boiler to run with the control thermostat phial temporarily removed from its pocket.**

| | | | | |
|--|--------|-------------------------|-------------------|-----------------|
| Safety Valve Setting | bar | 3.0 bar / 300 KPA | | |
| Vessel Charge & Initial System Pressure | bar | 0.5 bar / 5 KPA | 1.0 bar / 100 KPA | 1.5 bar 150 KPA |
| Total Water Content of System | litres | Expansion Vessel Volume | | |
| 25 | | 2.1 | 2.7 | 3.9 |
| 50 | | 4.2 | 5.4 | 7.8 |
| 75 | | 6.3 | 8.2 | 11.7 |
| 100 | | 8.3 | 10.9 | 15.6 |
| 125 | | 10.4 | 13.6 | 19.5 |
| 150 | | 12.5 | 16.3 | 23.4 |
| 175 | | 14.6 | 19.1 | 27.3 |
| 200 | | 16.7 | 21.8 | 31.2 |
| 225 | | 18.8 | 24.5 | 35.1 |
| 250 | | 20.8 | 27.2 | 39.0 |
| For system volumes other than those shown, multiply the total water content by the appropriate factor | factor | 0.0833 | 0.109 | 0.156 |
| For system models, deduct from the expansion vessel volume, given or calculated, the 12 litre vessel supplied. | | | | |
| To select the required vessel for the expansion vessel volume, choose the next rounded size larger from your supplier. | | | | |

OIL & OIL SUPPLY

6.1 Regulations

BS 5410: pt 1
BS 799: pt 5. Steel Tanks. OFST200.
OFS T100: Plastic Tanks.

BS 2871: pt 1 Table Y. Copper Tube.
BS 864: pt 2. Flared Fittings.
Building Regulations – Part L & J.

Other Technical Publications from OFTEC.

TI/130: Remote tank fill; terraced housing.
TI/131: Position of domestic tanks.
TI/133: Environmental spillage risk assessment.
TI/134: Underground oil supply pipes.

6.2 Fuels.

The burner is supplied set with the appropriate nozzle and pump pressure for the mid range of the boiler to fire **Class C2 Kerosene to BS2869 pt 2**,

The burner must not be modified to burn other fuels, unless Mistral Boilers is consulted with regard to suitability.

6.3 Oil supply pipes. **If MHG burner (blue flame also see burner manual)**

Oil enters the boiler side casing low down, either side to suit the installation. In the interests of safety, avoid passing the flexible burner oil line through the holes in the casing panels, the joint to the copper supply is made inside the casing.

The oil feed can be a single gravity feed, two pipe suction lift, or single pipe suction lift with DEAERATOR. Pipe work under the ground should be joint free and where appropriate use plastic covered copper tube. Exposed pipe work must be protected against accidental damage and fire.

Do not use solder fittings in the oil line.

Always flush out the oil line before connecting to the burner pump.

Components:

Oil filters should always be fitted to the oil line. One incorporated in the sight of the gauge assembly at the tank and another (of the paper element type) close by; but not inside, the boiler casing, especially if this is a replacement boiler installation using existing pipe work and tank.

Shut off cock, close to the boiler to allow burner and filter servicing, without draining down.

Fire valve, is an essential part of the installation. The valve should be located just outside the building at the point of entry. It is activated by a remote sensor phial which is positioned within the boiler casing and over the burner. The safe routing of the capillary tube to avoid accidental damage is important. Various lengths of capillary are available.

The use of solder head shut-off valves is not recommended.

Overfill alarms and remote contents gauges.

Overfill alarms are essential when the delivery point and vent pipe are remote from each other. Remote contents

• **Single pipe gravity feed (see 6.5.)**

If the oil outlet of the supply tank is above the burner, a single 10mm copper supply pipe line should be installed. This should include: an essential oil filter and remote sensor fire valve. At the burner the copper line is connected to oil pump via a flexible oil line to the suction port.

The burner is supplied from the factory set for single pipe gravity feed and does not have a bypass screw fitted.

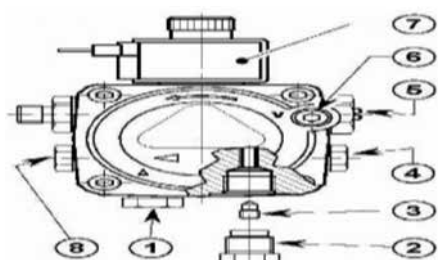

1. Suction Line
2. Return Line
3. By Pass Screw
4. Adjuster
5. Pressure valve
6. Suction Gauge Connection
7. Gauge Connection
8. Auxiliary Pressure test point

* From oil outlet to pump centre.

If the oil outlet of the supply tank is below the burner, a twin pipe 10mm copper supply system is suitable. This should include on the suction line: the essential oil filter, remote fire sensor and a spring loaded non - return oil valve.

Connections are to the suction and return ports of the burner pump via two flexible oil lines. The non-return valve prevents drain back to the supply tank which can occur during maintenance or after a long period of shut down.

The oil pump must have its internal bypass screw fitted. This is supplied loose with the burner.

The return line should terminate at the same level as the suction line and enter from the top of the tank; also within the tank the return line should have a small cut or hole to prevent siphoning.

No valves or restrictive fittings are to be fitted to the return line as they could blow the pump seals.

| Pipe runs (metres) and essential fittings | |
|---|------------------|
| Fire Valve | Yes |
| Filter | Yes |
| Non-return valve | Yes |
| Bypass screw | Yes fitted |
| Oil lift (metres) | 8mm I/D pipe run |
| 0 | 35 |
| 0.5 | 30 |
| 1 | 25 |
| 1.5 | 20 |
| 2 | 15 |
| 3 | 8 |
| 3.5 | 6 |
| Maximum lift | 4 metres |

• **Single pipe suction lift with DEAERATOR (see 6.5.)**

Where the oil line run for a two pipe system is long, or it is more convenient, a single suction line feed may be employed which includes an oil DEAERATOR with two pipe loop at the burner pump.

This device is located outside the building adjacent to the boiler. It may be higher or lower than the burner pump. No non-return valve is required.

Connections are a single pipe feed to the DEAERATOR and from here a flow and return connection to the boiler pump. The bypass screw is fitted. Pipe sizes may vary to suit the application.

The pump vacuum should not exceed 4 metres (0.4 bar) 40 KPA measured at the pump connection V. The pipe run table shows the TOTAL pipe length.

Bypass screw, return port location (Riello burner pump) the pump is supplied for use with a one pipe gravity feed oil supply line and the bypass screw is **not fitted** in the return port which is plugged.

For use on a two pipe suction lift system or where a DEAERATOR is used the bypass screw **must be fitted**.

If MHG burner (blue flame also see burner manual)

| Deaerator pipe runs* (metres) – Kerosene | | | |
|--|---------|---------|----------|
| Oil lift (metres) | 6mm O/D | 8mm O/D | 10mm O/D |
| 0 | 24 | 100 | 100 |
| 0.5 | 21 | 100 | 100 |
| 1 | 19 | 93 | 100 |
| 1.5 | 16 | 84 | 100 |
| 2 | 13 | 71 | 100 |
| 2.5 | 11 | 59 | 100 |
| 3 | 8 | 46 | 100 |
| 3.5 | 6 | 33 | 100 |
| 4max | - | 20 | 100 |

6.4 Oil Supply Diagrams.

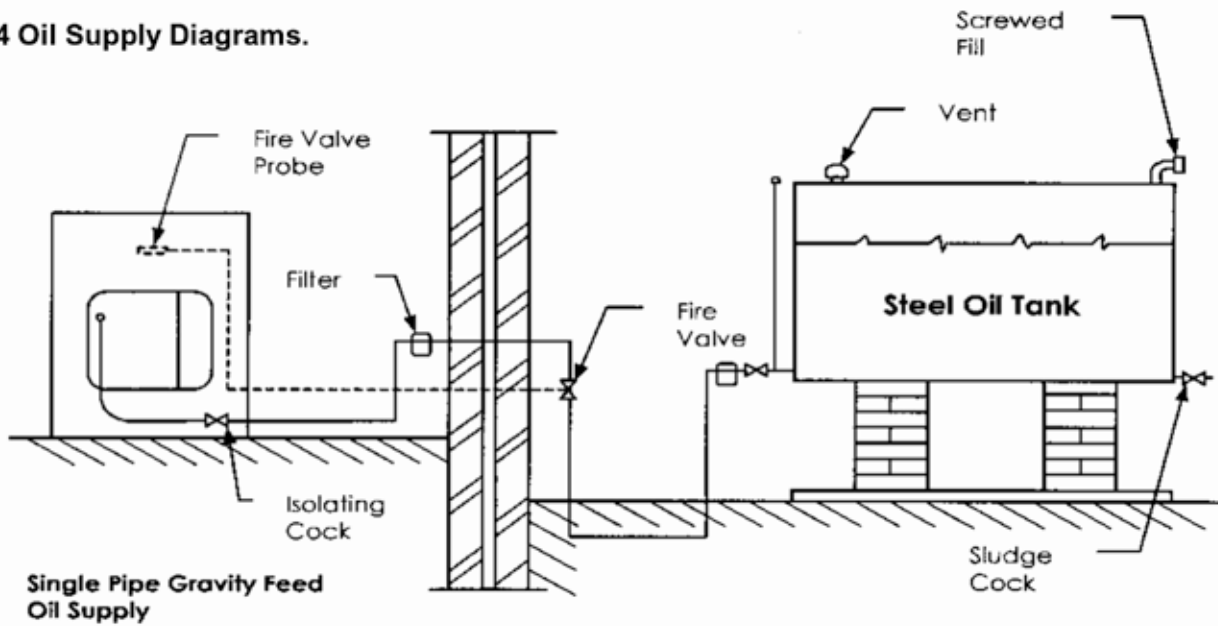

Single Pipe Gravity Feed Oil Supply

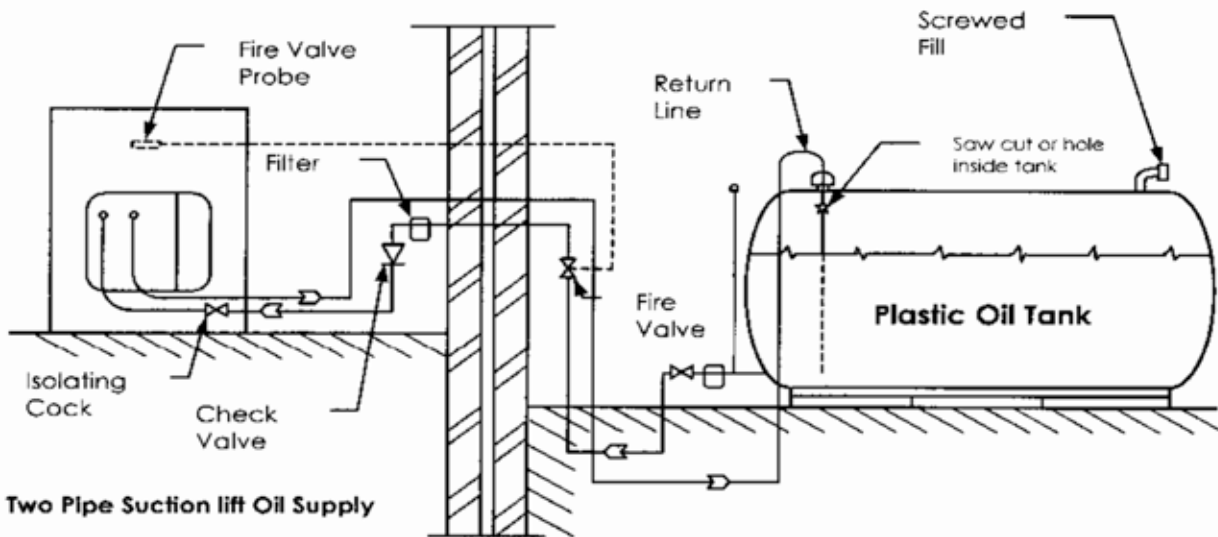

Two Pipe Suction lift Oil Supply

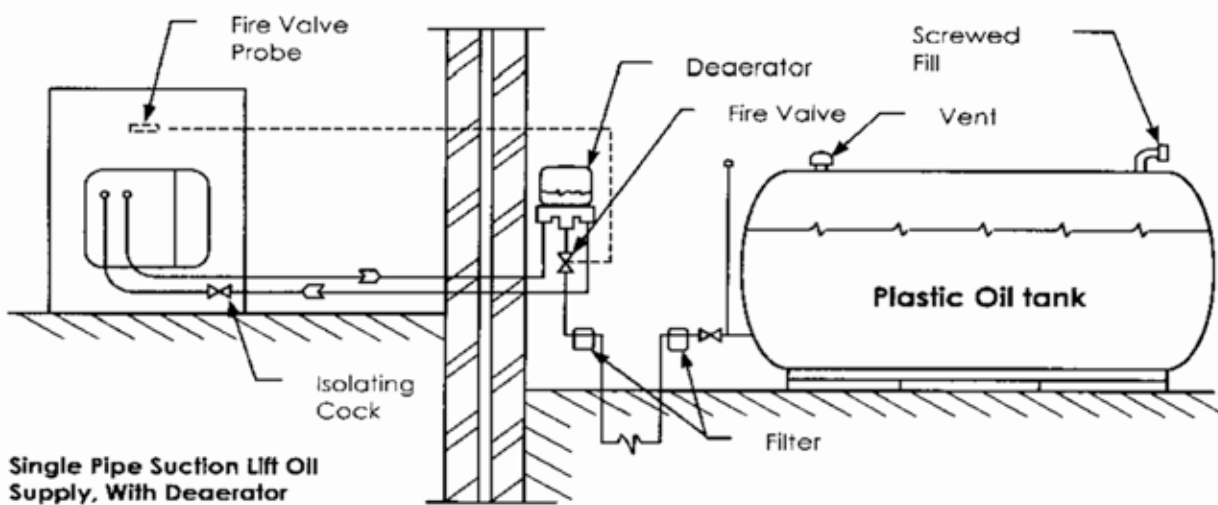

Single Pipe Suction Lift Oil Supply, With Deaerator

7.1. **Conventional options.** See also 4.4. Air for Combustion and Ventilation.

1. Connected to an existing chimney, should be suitably lined using a liner intended for oil condensing boilers. It is advisable to back-fill with insulation such as vermiculite.
2. Factory made double skinned and insulated flue systems, suitable for condensing boilers.

For further information on conventional flue, refer to flue manufacturers guide lines.

Draught. A conventional flue works because the air pressure at the top is less than at the bottom and the air surrounding the chimney pushes the air in the flue upwards to the top, causing the gasses to rise.

This flow is also assisted by lighter heated flue gasses from the boiler.

If the flue terminates in a region of positive pressure, as would be found below the ridge of a roof or below the eaves etc. then the gasses will be held back and spillage from the flue may occur at the bottom.

Compliance. The flue must comply with the requirements of Building Regulations Part J & L and BS5410. As down draught (inversion of the flue gasses) must be avoided, strict adherence to the regulations regarding termination does not guarantee satisfactory performance.

Design. The flue should terminate beyond the ridge or flat roof parapet. If terminating from within a brick chimney, the flue should extend to at least the height of a normal clay pot.

The use of a rain cap is recommended. Other types of pots and cowls that might restrict the efficient flow of combustion products should not be fitted and where found should be removed.

Special anti-down draught pots serve only to increase the effective height of the flue when installed in a positive pressure zone and should be avoided.

The connecting flue from the boiler to the main stack should not reduce the boiler take off size. Do not immediately exit the boiler, with a flue bend, a straight run of at least 600mm is advised. Bends should be kept to a minimum angle of 135° and where required those with clean-out covers are preferred.

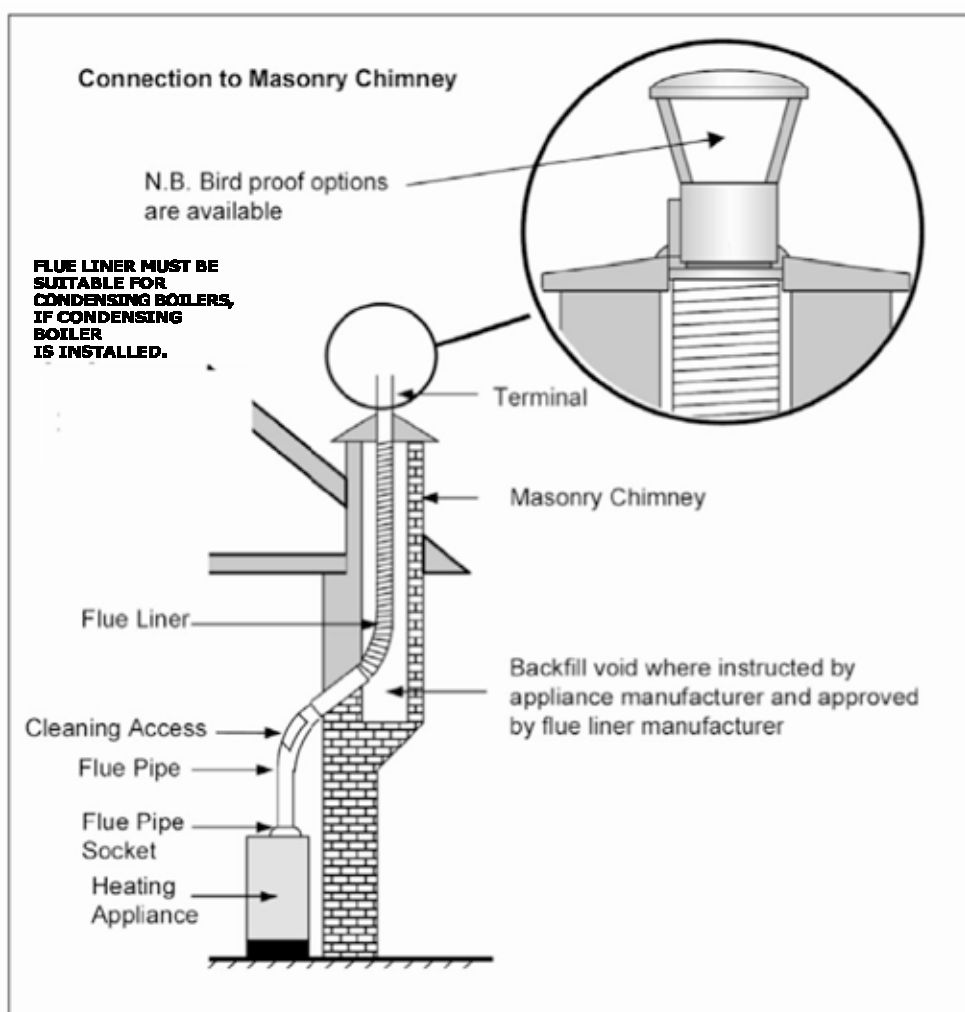

Never run the flue horizontally and always try to join into the main stack either vertically or at 45°.

To make the adaptor joint: The flue should be sealed to the boiler adaptor using the appropriate high temperature sealant.

7.2. **Balanced.** The range of balanced flue kits available for use with Mistral Boilers is:

- Low Level Horizontal rear and side outlet, from the same kit.
- High Level Horizontal rear and side outlet, from the same kit.
- Vertical kit for flat / garage or pitched roof installation.

On all balanced flues,

In some cases wind can blow flue products in to the air in take, resulting in burn errecycling, then soot. If this happens check flue position and sealing of flue.

If flue position or design cannot be changed, by using extensions or plumekits (see page 29 - 30.), sufficient air must be provided from an other source. The air supply to the burner can be from the room, if enough hair is available, or fit the flexible hose to a 75mm tube to take the air from outside. Burner must have clean air to work.

The requirements of the building regulations and BS 5410: pt 1 must be observed. However, if there is any doubt as to the suitability of a proposed flue location, please feel free to discuss this with our technical service department.

If any part of the balanced flue terminal after installation is lower than 2m from the ground, or can be touched, or is liable to damage, then a stainless steel **terminal guard** is required.

Terminal positions which are likely to be in close proximity to an oil tank must comply with the requirements for oil storage tanks in BS 5410, which is a clear distance of 1.8m and overrides the minimum dimensions for terminal positions shown in the table unless a fire-break is built.

The dimensions shown in the table are the minimum distances advised by BS 5410. However, where experience shows that a greater distance would be appropriate to give a more reliable installation, we have also given the greater dimension.

Terminal positions – best practice.

The terminal should be positioned on a generally flat surface and away from recesses or projecting features (external chimney structures) as these could well cause sufficient turbulence with the air to disturb b the efficient running of the boiler. The discharge from the terminal must be allowed to freely disperse. Where a terminal is less than 600mm from a plastic or combustible surface, then a heat shield is required to protect this surface.

Avoid discharging:

- Into a recreational area, such as a patio or play area.
 - Onto adjoining property, unless with permission.
 - Into a narrow passage way, particularly if it has a closed end.
 - In to a car port.
 - Directly into a public walkway.
 - Directly into a below ground level space (old coal shoot)
- Into an area where plants and shrubs will obviously grow and hinder the dispersal of the flue gas

Timber framed buildings are suitable for the installation of a horizontal balanced flue oil boiler. If the terminal passing through the frame is metal sleeved and at least 50mm greater than the flue and packed with heat resisting insulation, then each end should be capped with a metal plate for the flue to pass through and the outside sealed to prevent ingress of moisture.

The ceiling and roof timbers – vertical balanced flues.

- There must be no flue joints within the ceiling joist space.
- Joints must be at least 150mm below the ceiling.
- Where the flue passes through the ceiling, a means of securing the fire break must be retained.
- Flues which pass through habitable areas must be suitably boxed in to avoid a fire hazard. Please refer to your local building control officer for further advice.
- Section J & L of the Building Regulations must be followed.

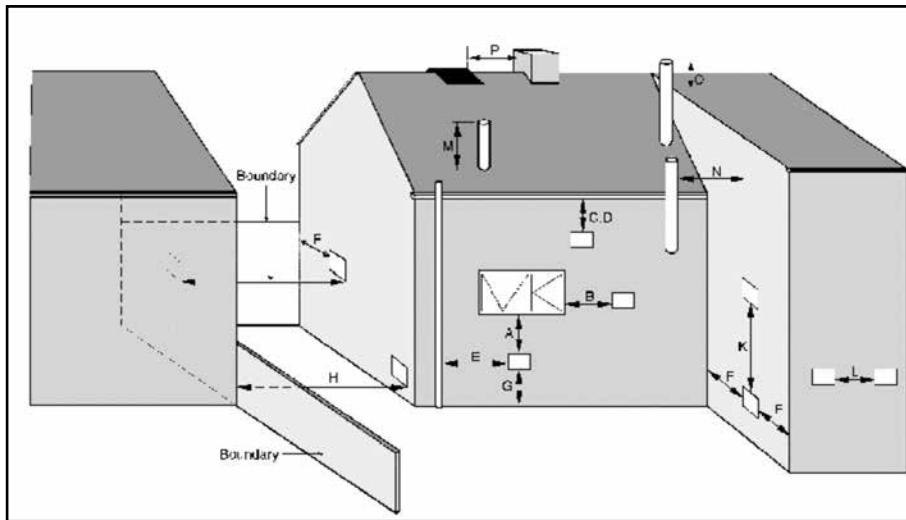

| | Recommended Minimum Balanced Flue Distances | In (mm) |
|---|--|---------|
| A | Directly below an opening, air brick, opening windows etc. | 600 |
| B | Horizontally to an opening, air brick, opening windows etc. | 600 |
| C | Below a gutter or a balcony without protection. | 600 |
| D | Below a gutter or a balcony with protection. | 75 |
| E | From a vertically sanitary pipe work. | 300 |
| F | From an internal or external corner or surface or boundary alongside terminal. | 300 |
| G | Above ground or balcony level. | 300 |
| H | From a surface or a boundary facing the terminal. | 600 |
| J | From a terminal facing the terminal. | 1200 |
| K | Vertically from a terminal on the same wall. | 1500 |
| L | Horizontally from a terminal on the same wall. | 750 |
| M | Above the highest point of an intersection with the roof. | 600 |
| N | From a vertical structure on the side of the terminal. | 750 |
| O | Above a vertical structure less than 750mm from the side of the terminal. | 600 |
| P | From a ridge terminal to vertical structure on the roof. | 1500 |

For outdoor models ensure that the factory fitted outlet is a minimum of 600mm (preferably 1000mm) away from any opening, door, window, and airbrick or from an overhang/gutter.

7.3 Balanced flue installation.

- The horizontal terminal

The circular flue terminal is flange mounted to the outside wall and is fixed in position with non rusting screws and wall plugs. Weather seal the reverse of the flange before securing to the wall, to stop rain penetration.

General installation and assembly.

All balanced flue options require the removal of the conventional flue terminal adaptor, where fitted, and the retention of the sealing gasket.

The balanced flue kits fit to the same four studs with the M8 nuts and washers.

Where tubes slide into each other it is important to lubricate the tube in order to protect the rubber seal from damage during assembly.

The horizontal terminal is designed to slope slightly backwards to enable as much condensation as possible to run back into the boiler trap.

The flue tubes are telescopic and generally do not require cutting.

Low level terminals have a connection that allows the flexible air tube to connect between the flue and air entry on the burner.

High level and vertical flues mount onto a stainless steel flue adaptor that also allows the flexible air tube to connect to the burner.

The air tube is an essential component and must be secured with the clips provided. Take care not to puncture the skin of the tube.

Due to the fact that all flue sections are fully adjustable please use the clamps provided to finish off or hold vertical sections in position prior to fitting the next vertical section.

Take care to ensure that the rubber internal flue seals do not snag whilst assembling as this will allow combustion gasses to leak and will effect the burner operation.

Condensing Appliance Flue Terminations

(Diagram 1.17)

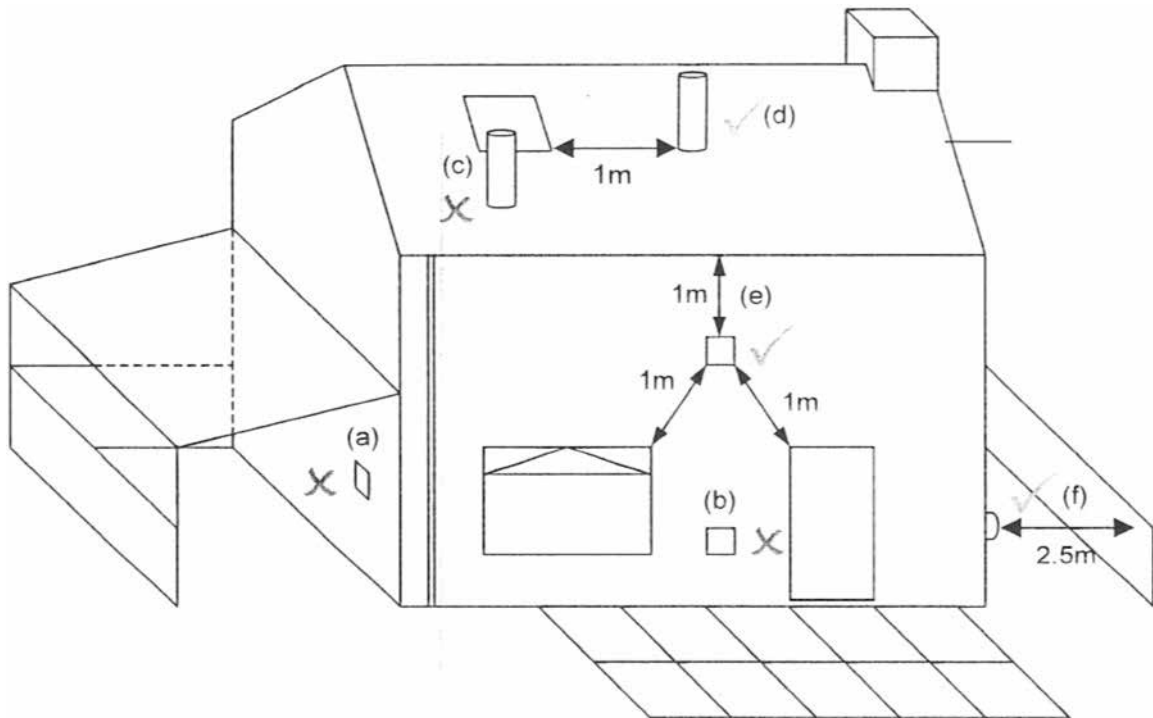

| | | |
|-----|---|---|
| (a) | Terminals must not be sited under car ports. | x |
| (b) | Terminals at low level (this is terminals under 2.1 mtr have more restrictive requirements and should not be positioned near public footways and frequently used access routes, car parking spaces less than 2.5mtr from the terminal or patio's (hard surface area). | x |
| (c) | Terminals should not be positioned under a roof window. | x |
| (d) | Terminals should be positioned at least 1 mtr from any side and top of a roof window. | / |
| (e) | Terminals should be positioned at least 1 mtr away from an opening and below a gutter, eaves or balcony, | / |
| (f) | Wall terminals should be sited a minimum of 2.5 mtr from any facing wall, fence, building or property boundary | / |

The Mistral KWIC-LOC balanced flue systems have been developed to provide for both fixed and individual flue design options. Utilizing the "O" ring seal and clip fixing system, allows all parts to be quickly assembled. Manufactured from high grade stainless steel the KWIC-LOC system and accessories are for balanced or conventional flue applications.

- ⊗ **Suitable for condensing and non condensing boilers**
- ⊗ **All flue are multi directional. Low level flues are concealed within the boiler casing, improving cosmetic appearance and helping to retain efficiency**
- ⊗ **Vertical, high & low level flue kit options, available with a full range of accessories, elbows, Flashings and adapters**
- ⊗ **Fixed and adjustable extensions provide for variable flue length requirements**

KWIC – LOC flue is available in 2 sizes to suit boilers 15 – 41 kw and 41 – 70 kw

Part Numbers 1541 = Boilers 15 - 41 kw (50 – 140,000 btu) Flue OD Diameter 120mm

Part Numbers 4168 = Boilers 41 - 70 kw (140 – 240,000 btu) Flue OD Diameter 150mm

Low Level, Vertical and High Level Kit options are supplied with the flue parts as illustrated, complete with the burner air hose & clips, seals, lubricant, boiler flue gasket, terminal guard, fixings and screws as applicable for the kit.

Plume elbow options are available that permit low level and outdoor boiler flues to be converted into the vertical position. This allows nuisance plumbing to be diverted away from windows or other obstructions. When a plume elbow is fitted, accessories from the vertical/high level flue range are used to complete the system.

Low level extensions (i.e. 1541 – HX – parts) can only be used with the low level flue system kits and these parts are not compatible for use with vertical and high level flue systems (i.e. 1541 – X – parts).

Local conditions, flue position and the overall flue length can have an adverse and a varying effect on the boiler performance. The boiler may require further adjustment to suit the site conditions.

For further information and advice on the Mistral KWIC – LOC flue system, please contact our technical sales office.

All Outdoor models come complete with single wall flue

Condensing Models - Plastic flue

Collar, upstand and elbow come factory fitted to boiler. Plastic flue lengths will have to be cut down to suit, left, right or rear exit, prior to basket being fitted.

Stainless steel flue

Stainless steel flue is intended to be used for left or right exit. If rear exit is required, the elbow will have to be cut to suit, prior to fitting basket.

Non-condensing Models - Stainless steel flue

Stainless steel flue is intended to be used for left or right exit. If rear exit is required, the elbow will have to be cut to suit, prior to fitting basket.

Plume accessories

Twin wall plume elbow can only exit left or right. As there will be no basket fitted, the single wall elbow will need to be cut, to allow plume elbow to fit flush with case.

LOW LEVEL BALANCED FLUE SYSTEM

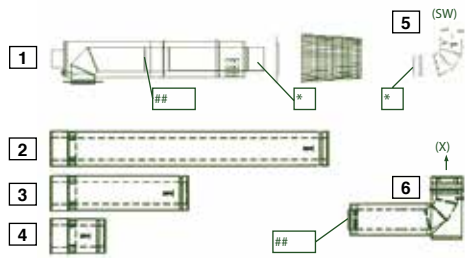

| | DESCRIPTION | 15-41KW | 41-68KW |
|---|-------------------------------|-------------------|--------------------|
| 1 | Low Level Balanced Flue (new) | 1541-BFK-4065 | 4168-BFK-4065 |
| 2 | 950mm Extension | 1541-HX-950 | 4168-HX-950 |
| 3 | 450mm Extension | 1541-HX-450 | 4168-HX-450 |
| 4 | 150mm Extension | 1541-HX-150 | 4168-HX-150 |
| 5 | 87 deg Single Wall Elbow | S0E9080-80-ELB-87 | S0E9100-100-ELB-87 |
| 6 | Plume Elbow | 1541-HX-90 | 4168-HX-90 |
| 7 | External Wall Bracket | 92940080 | 92940100 |

*. Starter elbow fits inside terminal section and is available in 80mm dia (15-41kw) and 100mm dia (41-58kw) ...maximum 2M
 ## Replaces the terminal section of the flue and available in 125mm dia (15-41kw) and 150mm dia (41-58kw) and to be used with (X) accessories only.

HIGH LEVEL AND VERTICAL BALANCE FLUE SYSTEMS

3000mm
VERTICAL
FLUE KIT
1541-VK-3000
4168-VK-3000

HIGH LEVEL
HORIZONTAL
FLUE KIT
1541-HHK-1100 T2
4168-HHK-1100 T2

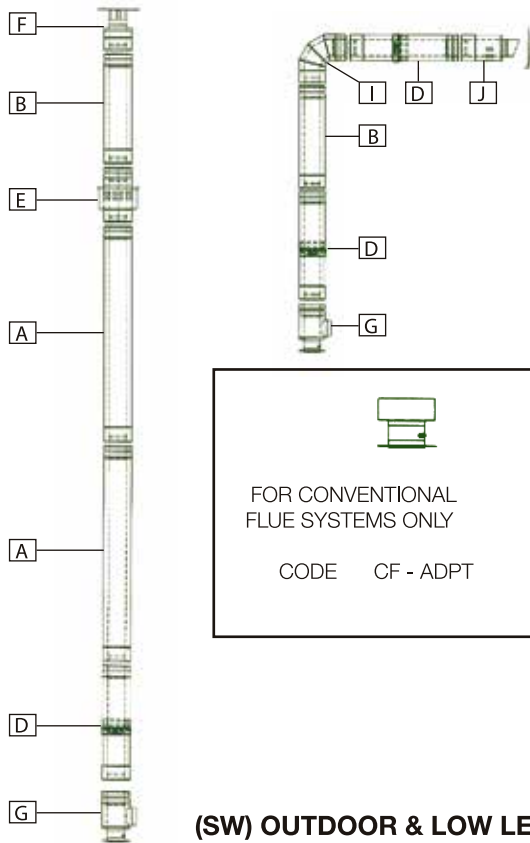

| | DESCRIPTION | 15-41 | 41-68 |
|---|--------------------------------|------------------|------------------|
| A | 950mm Extension (1 piece) | 1541-X-950 | 4168-X-950 |
| B | 450mm Extension (1 piece) | 1541-X-450 | 4168-X-450 |
| C | 150mm Extension (1 piece) | 1541-X-150 | 4168-X-150 |
| D | 240-440mm Adjustable Extension | 1541-AX-2442 | 4168-AX-2442 |
| E | Terminal Air Intake (Part 2) | 1541-BFRT (Pt 2) | 4168-BFRT (Pt 2) |
| F | Terminal Rain Cap (Part 1) | 1541-BFRT (Pt 1) | 4168-BFRT (Pt 1) |
| G | Boiler Adapter | 1541-BFBA | 4168-BFBA |
| H | 45 deg Bend | 1541-ELB-45 | 4168-ELB-45 |
| I | 90 deg Bend | 1541-ELB-90 | 4168-ELB-90 |
| J | Wall Terminal | 1541-HLHT | 4168-HLHT |
| K | Outdoor Plume Elbow | 1541-OD-ELB-90 | 4168-OD-ELB-90 |
| L | Terminal Discharge Elbow | 1541-TER-ELB-90 | 4168-TER-ELB-90 |
| M | Pitched Flashing | 1541-PRF | 4168-PRF |
| N | Flat Flashing | 1541-FRF | 4168-FRF |

BALANCE FLUE (X) ACCESSORIES

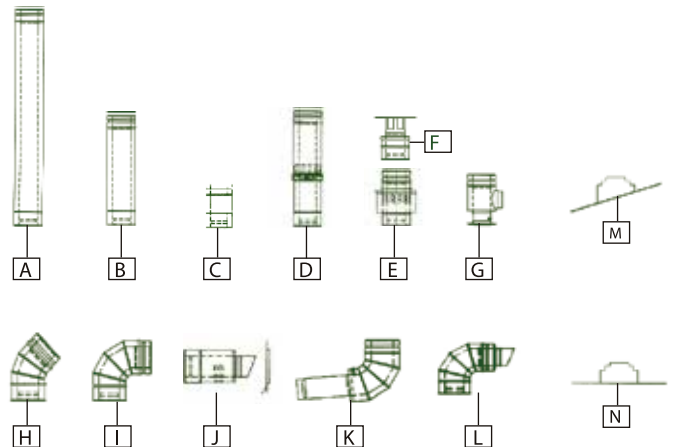

(SW) OUTDOOR & LOW LEVEL SINGLE WALL FLUE ACCESSORIES FOR VERTICAL AND HORIZONTAL APPLICATIONS

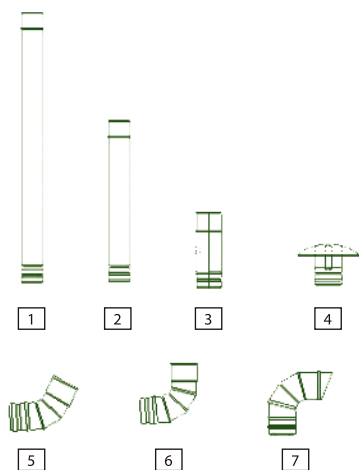

| | PRIMA PLUS S/S SINGLE WALL | CODE 80MM | CODE 100MM |
|---|-------------------------------|---------------------|----------------------|
| 1 | 1000MM EXTENSION | S001080-80-1000 | S001100-100-1000 |
| 2 | 500MM EXTENSION | S002080-80-500 | S002100-100-500 |
| 3 | TEST POINT (200MM) STRAIGHT | U1541ODTP-80-200 | U4168ODTP-100-200 |
| 4 | RAIN CAP | S036080-80-RAINCAP | S036100-100-RAINCAP |
| 5 | 45 DEG ELBOW | S015080-80-ELB-45 | S015100-100-ELB-45 |
| 6 | 87 DEG STARTER ELBOW | S0E9080-80-ELB-87 | S0E9100-100-ELB-87 |
| 7 | TERMINAL ELBOW | U1541ODTERMELB | U4168ODTERMELB |
| | SEALS | V0000080-80-SEALS | V000100-100-SEALS |
| | LOCKING BAND | S030080-80-LOCKBAND | S030100-100-LOCKBAND |
| | EXTERNAL WALL BRACKET | 92940080-80-EXTBAND | 92940100-100-EXTBAND |

BALANCED FLUE KIT DESCRIPTION

- BFK LOW LEVEL HORIZONTAL FLUE KIT.** Telescopic 2 part Flue Kit.
Includes: Boiler Adapter, Telescopic Terminal, Terminal Guard, Seals, Lubricant, Seals and Burner Air Hose & Clips.
- HHK HIGH LEVEL HORIZONTAL FLUE KIT.** 1100mm Vertical / 450mm Horizontal Flue Kit.
Includes: Boiler Adapter, 950mm Extension, 90° Elbow, 220-440mm Adjustable Extension, Wall Terminal, Lubricant, Seals and Burner Air Hose & Clips.
- VK 3000 VERTICAL FLUE KIT.** 3 Metre Vertical Flue Kit.
Includes: Boiler Adapter, 2 x 950mm Extension, 450mm extension, 220-440mm Adjustable Extension, Roof Terminal, Lubricant, Seals and Burner Air Hose & Clips.

RECOMMENDED MAXIMUM FLUE LENGTH GUIDE (Also see notes on page 42)

- LOW LEVEL HORIZONTAL:** Boilers 15 – 35 kw 2 Metres
Boilers 35 – 70 kw 1 Metre
- HIGH LEVEL HORIZONTAL:** Boilers 15 – 35 kw 4 Metres
Boilers 35 – 70 kw 3 Metres
- VERTICAL FLUE SYSTEM:** Boilers 15 – 35 kw 6 Metres
Boilers 35 – 70 kw 5 Metres

NOTE: It is not recommended that elbows totalling more than 90° are used in the complete flue system.

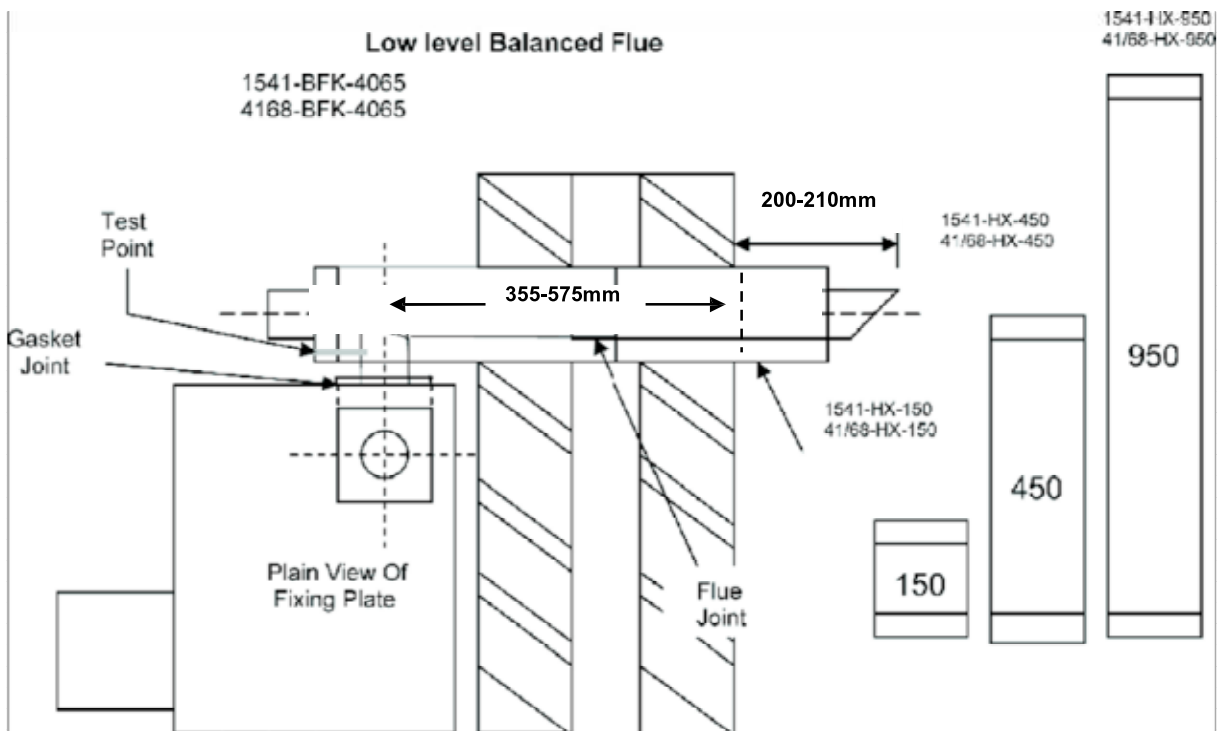

Mistral Plastic Flue System

The Mistral Plastic Flue system is versatile, easy to fit and extremely economical. It is suitable for our 15 / 41 kw. Condensing models in Balanced Flue complete systems and Single Wall Solutions where appropriate.

BALANCED FLUE SYSTEMS

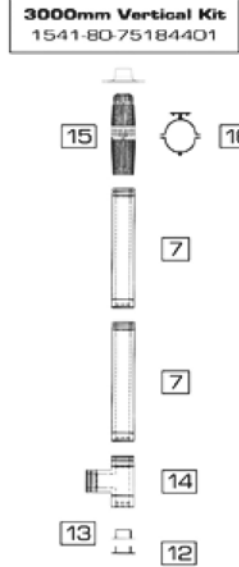
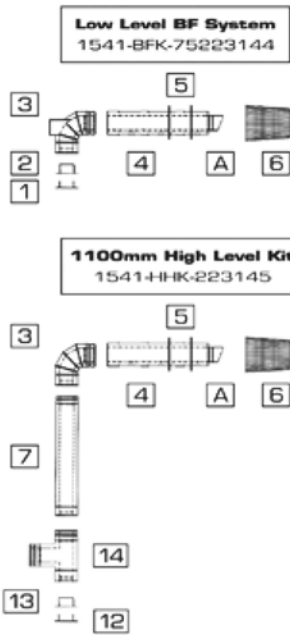

| | | |
|----|----------------------|------------------|
| 1 | Boiler adaptor | 1541-80-75710750 |
| 2 | Flue collar | 1541-80-7521345 |
| 3 | BF Boiler Elb. 90* | 1541-80-75228520 |
| 4 | BF with Air intake | 1541-80-7521346 |
| 5 | Collar x 2 | 1541-80-7521347 |
| 6 | Protective basket | 1541-80-7521348 |
| 7 | 1000mm Ext. | 1541-80-75228532 |
| 8 | 500mm Ext. | 1541-80-75228531 |
| 9 | 250mm Ext. | 1541-80-75228530 |
| 10 | Elbow 90* | 1541-80-75228520 |
| 11 | Elbow 45* | 1541-80-75228500 |
| 12 | Boiler adaptor | 1541-80-7521349 |
| 13 | Flue collar | 1541-80-7521350 |
| 14 | BF adaptor | 1541-80-7521351 |
| 15 | Air intake / exhaust | 1541-80-7521352 |
| 16 | Wall bkt. | 1541-80-75225701 |
| 17 | Wall bkt. BF Ext. | 1541-80-75225761 |
| A | Terminal End | 1541-80-7521353 |
| 18 | Pitched flashing | 1541-80-75174050 |
| 19 | Flat flashing | 1541-80-75146141 |



SINGLE WALL FLUE SYSTEMS

Can be used for better Plume dispersement on 15 / 41 kw. Balanced Flue Condensing boilers 15 / 41 kw.

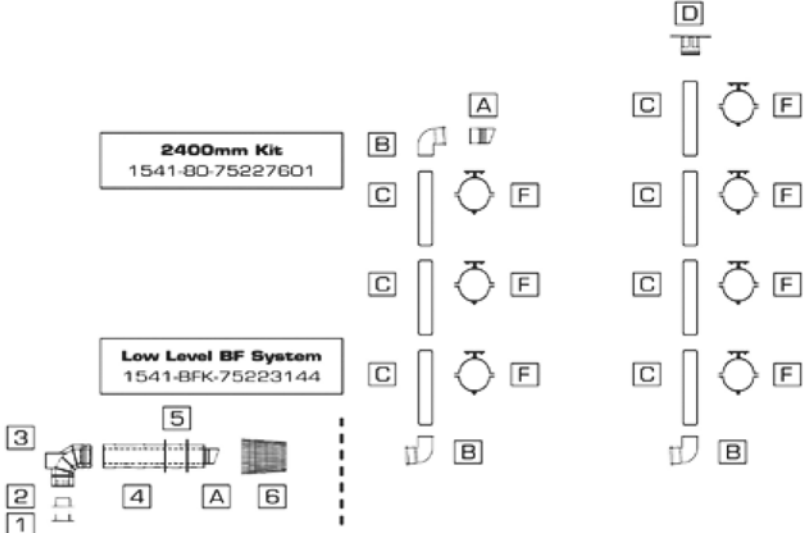

3200mm Kit
1541-80-75227602

| | | |
|---|----------------|----------------------|
| B | SW Elbow 90* | 201 100001038 |
| C | SW 800mm Ext. | 1541-80-7510083 |
| D | SW 800mm Ext. | 1541-80-7521354 |
| E | SW Elbow 45* | 1541-80-75222937 |
| F | Wall bkt. 80mm | 1541-80-100000169152 |

SINGLE WALL FLUE FOR OUTDOOR MODELS

To assist with Plume dispersement on Outdoor models, use either of the above Single Wall kits - 1) 2400mm kit, or 2) 3200mm kit. Alternatively, you can make your own kit from our accessories list.

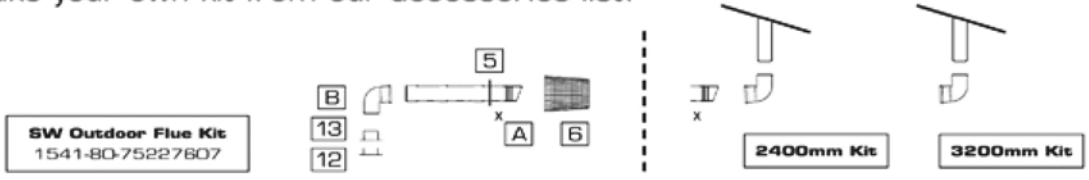

ECODESIGN DIRECTIVE

European Energy Related Products Directive (ERP)

As part of the Ecodesign Directive, the ERP comes into effect in Sept. 2015. The overall objective is to reduce carbon emissions, restrict other environmental impacts and encourage the development of products which will increase energy efficiencies.

The ERP has set minimum standards to be achieved for boilers and as such, some products will no longer be available for installation after this time. The products which reach the accepted criteria, will be subject to a new labelling system, examples of which are shown below.

The new Energy Label will accompany the boiler, however, if it is to be part of a greater system containing different products, an overall Package label will be supplied which shows a combined system efficiency. This may be supplied by either the merchant or the installer and is known as a Product Fiche.

The Label will contain certain information relating to the specific product, such as the Manufacturers name, product code, power output, noise level.

The other important information contained within the label is the following symbols ;

- 1/ Radiator – refers to Heating and the letter “A” denotes the Efficiency Class
- 2/ Tap – refers to Domestic Hot Water and the letter “B” is the Efficiency Class

On a Heat only boiler only the radiator will be seen, whereas both items will be shown on a Combi. Both examples below show a Condensing and a Non Condensing Boiler and the different Classes they will be categorised in.

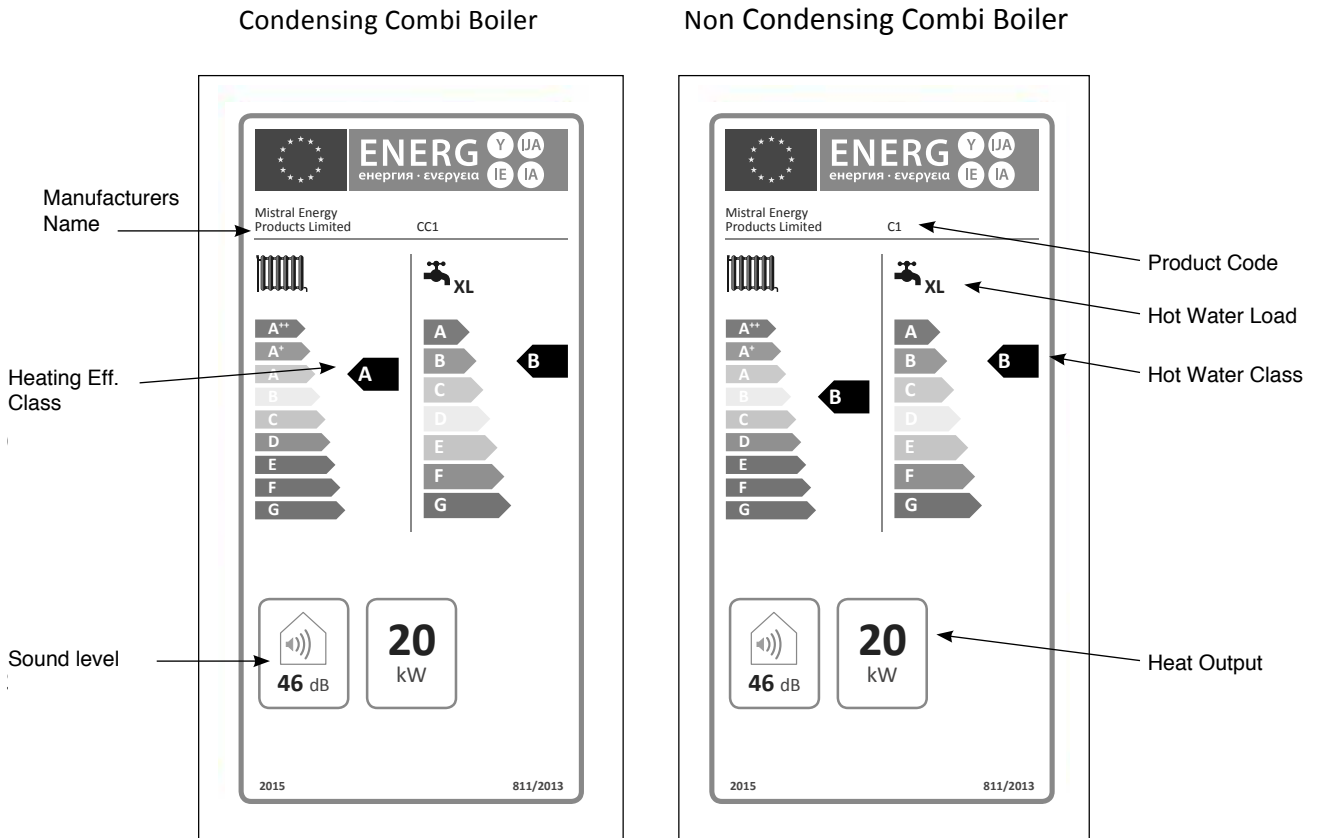

| CONDENSING | | | | Rated Heat | ERP Seasonal Efficiency | Hot Water Efficiency | Hot Water Load | Nox level maximum | Sound |
|-----------------|-------|-----------|-----------|------------|-------------------------------|-------------------------|-------------------|----------------------|-------|
| MODEL | Code | ERP Class | ERP Class | Output | | | | mg/kwh. | Sound |
| | | Hot Water | Heat only | P rated | Ns | Nwh | | | LWA |
| KITCHEN UTILITY | | | | | | | | | |
| | | | | | % | | | | Dbi. |
| CKUT1 | 15/20 | | A | 20 | 92.00 | | | 120 | 46.00 |
| CKUT2 | 20/26 | | A | 26 | 92.00 | | | 120 | 46.00 |
| CKUT3 | 26/35 | | A | 35 | 92.00 | | | 120 | 48.00 |
| CKUT4 | 35/41 | | A | 41 | 92.00 | | | 120 | 48.00 |
| CKUT5 | 41/50 | | A | 50 | 90.00 | | | 120 | 48.00 |
| CKUT6 | 50/58 | | A | 58 | 90.00 | | | 120 | 48.00 |
| CKUT7 | 58/70 | | A | 70 | 90.00 | | | 120 | 48.00 |
| SEALED SYSTEM | | | | | | | | | |
| CS1 | 15/20 | | A | 20 | 92.00 | | | 120 | 46.00 |
| CS2 | 20/26 | | A | 26 | 92.00 | | | 120 | 46.00 |
| CS3 | 26/35 | | A | 35 | 92.00 | | | 120 | 48.00 |
| CS4 | 35/41 | | A | 41 | 92.00 | | | 120 | 48.00 |
| COMBI STD | | | | | | | | | |
| CC1 | 15/20 | B | A | 20 | 92.00 | 68.00 | XL | 120 | 46.00 |
| CC2 | 20/26 | B | A | 26 | 92.00 | 73.00 | XL | 120 | 46.00 |
| CC3 | 26/35 | B | A | 35 | 92.00 | 77.00 | XXL | 120 | 48.00 |
| CC4 | 35/41 | B | A | 41 | 92.00 | 78.00 | XXL | 120 | 48.00 |
| CMC5 | 41/50 | B | A | 50 | 90.00 | 73.00 | XXL | 120 | 48.00 |
| CMC6 | 50/58 | B | A | 58 | 90.00 | 74.00 | XXL | 120 | 48.00 |
| CMC7 | 58/70 | B | A | 70 | 90.00 | 74.00 | XXL | 120 | 48.00 |
| COMBI PLUS | | | | | | | | | |
| CC1 + | 15/20 | B | A | 20 | 92.00 | 68.00 | XL | 120 | 46.00 |
| CC2 + | 20/26 | B | A | 26 | 92.00 | 73.00 | XL | 120 | 46.00 |
| CC3 + | 26/35 | B | A | 35 | 92.00 | 77.00 | XXL | 120 | 48.00 |
| CC4 + | 35/41 | B | A | 41 | 92.00 | 78.00 | XXL | 120 | 48.00 |
| CMC5 + | 41/50 | B | A | 50 | 90.00 | 73.00 | XXL | 120 | 48.00 |
| CMC6 + | 50/58 | B | A | 58 | 90.00 | 74.00 | XXL | 120 | 48.00 |
| CMC7 + | 58/70 | B | A | 70 | 90.00 | 74.00 | XXL | 120 | 48.00 |
| BOILER HOUSE | | | | | | | | | |
| CBH1 | 15/20 | | A | 20 | 92.00 | | | 120 | 46.00 |
| CBH2 | 20/26 | | A | 26 | 92.00 | | | 120 | 46.00 |
| CBH3 | 26/35 | | A | 35 | 92.00 | | | 120 | 48.00 |
| CBH4 | 35/41 | | A | 41 | 92.00 | | | 120 | 48.00 |
| CBH5 | 41/50 | | A | 50 | 90.00 | | | 120 | 48.00 |
| CBH6 | 50/58 | | A | 58 | 90.00 | | | 120 | 48.00 |
| CBH7 | 58/70 | | A | 70 | 90.00 | | | 120 | 48.00 |
| O/D UTILITY | | | | | | | | | |
| COD1 | 15/20 | | A | 20 | 92.00 | | | 120 | 46.00 |
| COD2 | 20/26 | | A | 26 | 92.00 | | | 120 | 46.00 |
| COD3 | 26/35 | | A | 35 | 92.00 | | | 120 | 48.00 |
| COD4 | 35/41 | | A | 41 | 92.00 | | | 120 | 48.00 |
| COD5 | 41/50 | | A | 50 | 90.00 | | | 120 | 48.00 |
| COD6 | 50/58 | | A | 58 | 90.00 | | | 120 | 48.00 |
| COD7 | 58/70 | | A | 70 | 90.00 | | | 120 | 48.00 |
| O/D SYSTEM | | | | | | | | | |
| COD SS1 | 15/20 | | A | 20 | 92.00 | | | 120 | 46.00 |
| COD SS2 | 20/26 | | A | 26 | 92.00 | | | 120 | 46.00 |
| COD SS3 | 26/35 | | A | 35 | 92.00 | | | 120 | 48.00 |
| COD SS4 | 35/41 | | A | 41 | 92.00 | | | 120 | 48.00 |
| O/D COMBI STD | | | | | | | | | |
| CODC1 | 15/20 | B | A | 20 | 92.00 | 68.00 | XL | 120 | 46.00 |
| CODC2 | 20/26 | B | A | 26 | 92.00 | 73.00 | XL | 120 | 46.00 |
| CODC3 | 26/35 | B | A | 35 | 92.00 | 77.00 | XXL | 120 | 48.00 |
| CODC4 | 35/41 | B | A | 41 | 92.00 | 78.00 | XXL | 120 | 48.00 |
| CODMC5 | 41/50 | B | A | 50 | 90.00 | 73.00 | XXL | 120 | 48.00 |
| CODMC6 | 50/58 | B | A | 58 | 90.00 | 74.00 | XXL | 120 | 48.00 |
| CODMC7 | 58/70 | B | A | 70 | 90.00 | 74.00 | XXL | 120 | 48.00 |
| O/D COMBI PLUS | | | | | | | | | |
| CODC1 + | 15/20 | B | A | 20 | 92.00 | 68.00 | XL | 120 | 46.00 |
| CODC2 + | 20/26 | B | A | 26 | 92.00 | 73.00 | XL | 120 | 46.00 |
| CODC3 + | 26/35 | B | A | 35 | 92.00 | 77.00 | XXL | 120 | 48.00 |
| CODC4 + | 35/41 | B | A | 41 | 92.00 | 78.00 | XXL | 120 | 48.00 |
| CODMC5 + | 41/50 | B | A | 50 | 90.00 | 73.00 | XXL | 120 | 48.00 |
| CODMC6 + | 50/58 | B | A | 58 | 90.00 | 74.00 | XXL | 120 | 48.00 |
| CODMC7 + | 58/70 | B | A | 70 | 90.00 | 74.00 | XXL | 120 | 48.00 |

MISTRAL ENERGY PRODUCTS LTD.

| NON CONDENSING | | | | Rated Heat | ERP Seasonal Efficiency | Hot Water Efficiency | Hot Water Load | Nox level maximum | Sound |
|------------------------|-------|-----------|-----------|------------|-------------------------|----------------------|----------------|-------------------|-------------|
| MODEL | Code | ERP Class | ERP Class | Output | | | | mg/kwh. | |
| | | Hot Water | Heat only | P rated | Ns | Nwh | | | LWA |
| KITCHEN UTILITY | | | | | % | | | | Dbi. |
| KUT1 | 15/20 | | B | 20 | 87.00 | | | 120 | 46.00 |
| KUT2 | 20/26 | | B | 26 | 87.00 | | | 120 | 46.00 |
| KUT3 | 26/35 | | B | 35 | 87.00 | | | 120 | 48.00 |
| KUT4 | 35/41 | | B | 41 | 87.00 | | | 120 | 48.00 |
| KUT5 | 41/50 | | B | 50 | 86.00 | | | 120 | 48.00 |
| KUT6 | 50/58 | | B | 58 | 86.00 | | | 120 | 48.00 |
| KUT7 | 58/70 | | B | 70 | 86.00 | | | 120 | 48.00 |
| SEALED SYSTEM | | | | | | | | | |
| S1 | 15/20 | | B | 20 | 87.00 | | | 120 | 46.00 |
| S2 | 20/26 | | B | 26 | 87.00 | | | 120 | 46.00 |
| S3 | 26/35 | | B | 35 | 87.00 | | | 120 | 48.00 |
| S4 | 35/41 | | B | 41 | 87.00 | | | 120 | 48.00 |
| COMBI STD | | | | | | | | | |
| C1 | 15/20 | B | B | 20 | 87.00 | 60.00 | XL | 120 | 46.00 |
| C2 | 20/26 | B | B | 26 | 87.00 | 64.00 | XL | 120 | 46.00 |
| C3 | 26/35 | B | B | 35 | 87.00 | 67.00 | XXL | 120 | 48.00 |
| C4 | 35/41 | B | B | 41 | 87.00 | 68.00 | XXL | 120 | 48.00 |
| MC5 | 41/50 | B | B | 50 | 86.00 | 63.00 | XXL | 120 | 48.00 |
| MC6 | 50/58 | B | B | 58 | 86.00 | 64.00 | XXL | 120 | 48.00 |
| MC7 | 58/70 | B | B | 70 | 86.00 | 65.00 | XXL | 120 | 48.00 |
| COMBI PLUS | | | | | | | | | |
| C1 + | 15/20 | B | B | 20 | 87.00 | 60.00 | XL | 120 | 46.00 |
| C2 + | 20/26 | B | B | 26 | 87.00 | 64.00 | XL | 120 | 46.00 |
| C3 + | 26/35 | B | B | 35 | 87.00 | 67.00 | XXL | 120 | 48.00 |
| C4 + | 35/41 | B | B | 41 | 87.00 | 68.00 | XXL | 120 | 48.00 |
| MC5 + | 41/50 | B | B | 50 | 86.00 | 63.00 | XXL | 120 | 48.00 |
| MC6 + | 50/58 | B | B | 58 | 86.00 | 64.00 | XXL | 120 | 48.00 |
| MC7 + | 58/70 | B | B | 70 | 86.00 | 65.00 | XXL | 120 | 48.00 |
| BOILER HOUSE | | | | | | | | | |
| BH1 | 15/20 | | B | 20 | 87.00 | | | 120 | 46.00 |
| BH2 | 20/26 | | B | 26 | 87.00 | | | 120 | 46.00 |
| BH3 | 26/35 | | B | 35 | 87.00 | | | 120 | 48.00 |
| BH4 | 35/41 | | B | 41 | 87.00 | | | 120 | 48.00 |
| BH5 | 41/50 | | B | 50 | 86.00 | | | 120 | 48.00 |
| BH6 | 50/58 | | B | 58 | 86.00 | | | 120 | 48.00 |
| BH7 | 58/70 | | B | 70 | 86.00 | | | 120 | 48.00 |
| O/D UTILITY | | | | | | | | | |
| OD1 | 15/20 | | B | 20 | 87.00 | | | 120 | 46.00 |
| OD2 | 20/26 | | B | 26 | 87.00 | | | 120 | 46.00 |
| OD3 | 26/35 | | B | 35 | 87.00 | | | 120 | 48.00 |
| OD4 | 35/41 | | B | 41 | 87.00 | | | 120 | 48.00 |
| OD5 | 41/50 | | B | 50 | 86.00 | | | 120 | 48.00 |
| OD6 | 50/58 | | B | 58 | 86.00 | | | 120 | 48.00 |
| OD7 | 58/70 | | B | 70 | 86.00 | | | 120 | 48.00 |
| O/D SYSTEM | | | | | | | | | |
| OD SS1 | 15/20 | | B | 20 | 87.00 | | | 120 | 46.00 |
| OD SS2 | 20/26 | | B | 26 | 87.00 | | | 120 | 46.00 |
| OD SS3 | 26/35 | | B | 35 | 87.00 | | | 120 | 48.00 |
| OD SS4 | 35/41 | | B | 41 | 87.00 | | | 120 | 48.00 |
| O/D COMBI STD | | | | | | | | | |
| ODC1 | 15/20 | B | B | 20 | 87.00 | 60.00 | XL | 120 | 46.00 |
| ODC2 | 20/26 | B | B | 26 | 87.00 | 64.00 | XL | 120 | 46.00 |
| ODC3 | 26/35 | B | B | 35 | 87.00 | 67.00 | XXL | 120 | 48.00 |
| ODC4 | 35/41 | B | B | 41 | 87.00 | 68.00 | XXL | 120 | 48.00 |
| ODMC5 | 41/50 | B | B | 50 | 86.00 | 63.00 | XXL | 120 | 48.00 |
| ODMC6 | 50/58 | B | B | 58 | 86.00 | 64.00 | XXL | 120 | 48.00 |
| ODMC7 | 58/70 | B | B | 70 | 86.00 | 65.00 | XXL | 120 | 48.00 |
| O/D COMBI PLUS | | | | | | | | | |
| ODC1 + | 15/20 | B | B | 20 | 87.00 | 60.00 | XL | 120 | 46.00 |
| ODC2 + | 20/26 | B | B | 26 | 87.00 | 64.00 | XL | 120 | 46.00 |
| ODC3 + | 26/35 | B | B | 35 | 87.00 | 67.00 | XXL | 120 | 48.00 |
| ODC4 + | 35/41 | B | B | 41 | 87.00 | 68.00 | XXL | 120 | 48.00 |
| ODMC5 + | 41/50 | B | B | 50 | 86.00 | 63.00 | XXL | 120 | 48.00 |
| ODMC6 + | 50/58 | B | B | 58 | 86.00 | 64.00 | XXL | 120 | 48.00 |
| ODMC7 + | 58/70 | B | B | 70 | 86.00 | 65.00 | XXL | 120 | 48.00 |

Condensing drain pipe from boiler.
Plastic drain pipe not supplied.

The boiler is usually supplied with one drain on the left hand side.

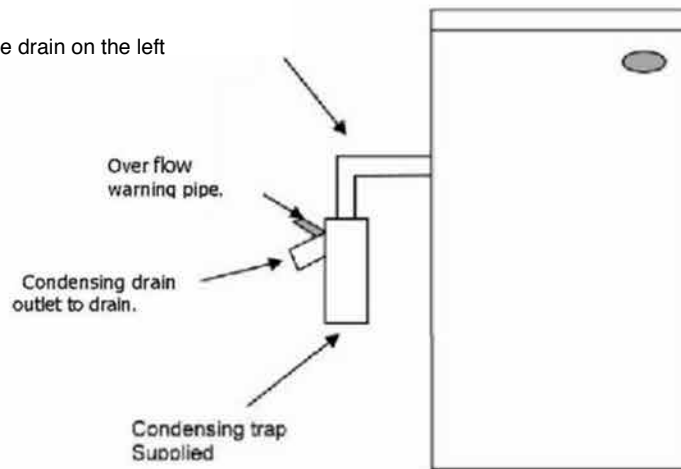

Condensate Drain

Condensate pipes must be fitted with a trap whether they are connected internally or externally. If a pipe runs into a gully or rainwater hopper the seal depth required is 38mm. If it is run into a waste pipe a 75mm deep seal is required. This trap is supplied as part of the boiler but the depth should always be checked to ensure that it complies with the above requirements.

Condensate can be easily disposed of either internally, connecting the condensate drain from the boiler to an internal domestic waste system or externally to a gully, hopper or soak-away.

Condensate pipes should be kept as short as possible, particularly external runs or where the pipes pass through unheated areas. They should be provided with a fall of 2.5 degrees away from the boiler. Plastic pipes used for rainwater or waste water are suitable to carry condensate. Copper or steel pipes should not be used.

Internal Connection to a Main Drainage Stack

Internal connection is the preferred method as risk of freezing is very greatly reduced. Connection to a main stack should be made at least 450mm above the invert at the bottom of the slack for dwellings up to 3 storeys. For taller buildings expert advice should be sought. The connection should not be made in a way that could enable cross flow to occur with an existing waste connection.

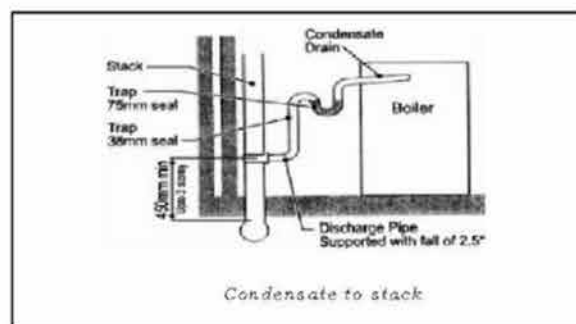

Internal Connection to a Waste Pipe

Connection can be made into an internal waste branch such as it is connected to appliances or sinks in a kitchen. It is best to connect into the upper part of the pipe. An air break has to be provided between a sink and the boiler trap if connection is made upstream of the sink trap. If the sink has an integral overflow then this will provide the required air break. If an air break is provided, it and the boiler trap must be located above the level of the sink to prevent any flow from the sink into the boiler or air break.

Connection to appliances such as washing machines is preferable to sink connection as the risk of blockage is less.

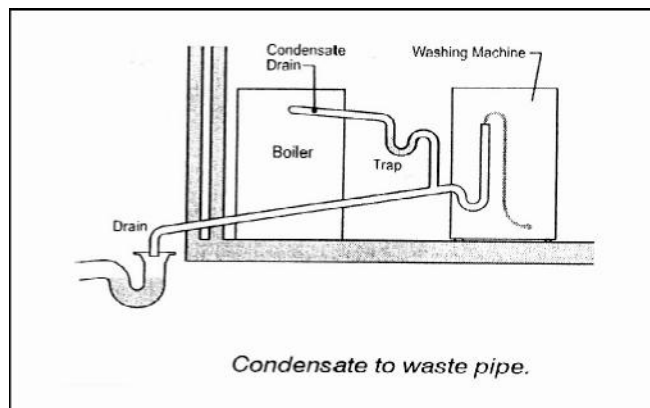

External Connection to a Soak-away

Connection to a purpose made soak-away is an alternative method of disposing of boiler condensate. As with all external connections exposed pipe work should be kept as short as possible. The condensate pipe can be run into a piece of plastic drain pipe, sealed at the top and provided with side holes which are faced away from the building. The overall size of the soak-away hole can be of about 200mm diameter and 400mm depth. It should be filled with limestone chippings.

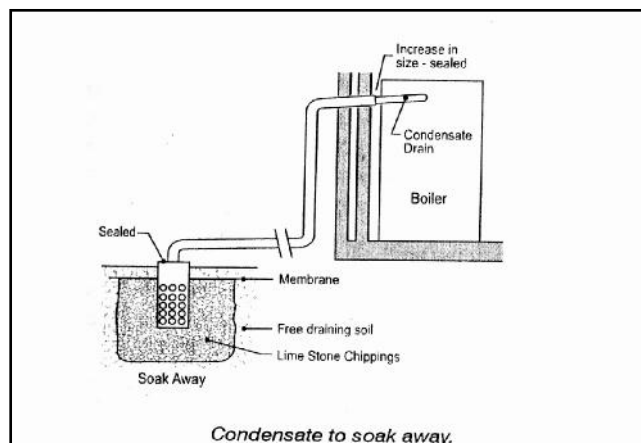

External Connection to a Drain

Connection to an external drainage stack, gully or rainwater hopper can be considered. Connections to stacks should be undertaken carefully so as to eliminate the possibility of the condensate freezing and blocking the stack. Where a gully or hopper is used the condensate pipe should be terminated below the grid level but above water level.

It should be noted that condensate should not be disposed of in grey water systems

COMMISSIONING / SERVICING & MAINTENANCE

References BS5410: pt 1. OFTEC BOOK 2.

OFTEC TI/133 Domestic oil tank, environmental risk assessment.

See also Sealed Systems SECTION 5.7. System Filling and commissioning.

9.1 The boiler has been supplied and tested for mid range of the boiler. As site conditions will influence the operation of the boiler, these factory settings require final adjustment.

- Correctly installed and set up for first firing, Mistral boilers will provide long, efficient and reliable service. It is required that the appliance should be serviced minimum every 12 months.
- Whilst every effort has been made to give the correct installation advice within this manual, the commissioning of these boilers requires some expert knowledge.
- To comply with the building regulations this boiler must be commissioned by an OFTEC or suitably approved engineer.
- Once the boiler has been tested and your report has been compiled, it is recommended that you highlight to the person requesting the work, any deviations and errors that may require attention. If it is safety related, please advise an appropriate course of action.
- The following check list should be undertaken before the commissioning tests are undertaken. The sequence is as outlined in the OFTEC book 2.
- OFTEC form CD11 should be completed and a copy left with house holder. Please also fill in the information at the back of this book.

9.2 Commissioning appliance

- Ensure there is no air in the heating system, and system has been flushed and treated with inhibitor.
- Check trap is purged.
- Remove inspection door on main heat exchanger, and condensing unit, and check baffles
- Remove burner and check settings / nozzle. Please refer to burner manual for correct settings.
- Turn electrical supply, to the boiler ON.
- Set the central heating controls so they are calling for heat
- Purge air from oil line supply.
- Check oil pump pressure adjust if required.
- Check smoke reading.
- Measure the Co and adjust air on burner accordingly.
- Ensure appliance is up to working temperature. Failure to do so may incur incorrect combustion settings
- Non condensing boilers; it is preferable for the flue gas to exceed 150 °c. If this is not the case, this can result in more condensation entering the boiler, and in order to overcome this, it is possible to remove perhaps the top 2 baffles to obtain optimum flue gas temp.

9.3 General:

It is advisable to check that the condense trap is topped up with water on a monthly basis.

There are certain parts which will require inspection and possible replacement at the time of service.

- Oil burner nozzle, must be replaced with the same specification.
Never attempt to strip and clean the nozzle, as this will lead to further difficulties and further expense.
- The oil lines must be inspected for hardening of the liner and possible leaks through the braiding. If either condition exists, replace the hose. You are advised to replace anyway every two years.
Fuel oil filter cartridge - rinse clean, or replace with the paper element type. Clean the bowl, inspect the bowl seal for swelling or cracks, and replace if necessary. Re-assemble taking care not to misplace the seal.
- Access door seals. The seal must be complete and provide a sound gas tight seal.
Condense heat exchanger flue ways and trap is clear of any blockage.

Servicing procedure.

These tasks should be undertaken by an OFTEC registered or suitably qualified engineer who is equipped with the necessary tools and combustion testing equipment.

1. Before switching off the boiler and before starting the service, it is advisable to observe the boiler running, to get a general idea of its condition.
2. **OIL STORAGE.**
Examine the oil supply tank and associated pipe work for signs of leakage or corrosion.
Check the support piers and the fill and vent connections. Inspect the sight gauge operation and for any damage or water ingress. For metal tanks check the plugged drain valve for water or sludge, pump out or run off as necessary but not onto the soil.

3. **OIL SUPPLY.**
Check exposed pipe work for damage or deterioration.
Examine the function of any non-return valve, fire valve (hot water test) or deaerator etc. Clean oil filters.
Inspect the flexible oil lines.
4. **AIR SUPPLY.**
Check the combustion air and ventilation openings are clear of lint or debris.
For balanced terminals see that no obstructions have been placed near the terminal and no shrubbery has grown up, which would hinder its operation. See that no additional air extraction has been added to the dwelling which could affect the operation of the appliance.
5. **FLUES and CHIMNEYS.** Inspect and clean as necessary conventional flues to the first bend. Ensure the flue has no build-up of soot or debris.
6. **THE BOILER.**
Servicing is from the front.
For Sealed System boilers, remove the expansion vessel and lay to one side. Before removing the burner, carefully disconnect the flexible air duct, by undoing the clip at the burner air entry, turn off the oil supply cock and remove the flexible oil lines. Unplug the burner lead at the control panel and remove the burner. Undo the access covers, remove and clean all baffles, noting the order in which they were positioned. Clean the heat transfer surfaces in the boiler and vacuum out all loose debris.
Inspect the burner gasket and access cover seals and replace if necessary.
7. **THE BURNER. If MHG burner (blue flame also see burner manual)**
Remove the blast tube and clean internally and externally.
Remove the electrode assembly and inspect for grazing or cracks in the ceramic. Clean and replace.
Remove old nozzle and discard. Refit new nozzle of the same make, pattern and capacity as specified in the technical data. Brush clean the fan blades of any dust build-up.
Inspect and clean the oil pumps filter. Check the condition of the photoelectric cell for signs of discolouration, clean and replace as necessary.
8. **BOILER SECURITY and COMBUSTION.**
Refit burner, re-connect the flexible oil line, burner lead and air hose.
Attach a pressure gauge (0-20bar) 0-200 KPA air bleed manifold to correct the pump connection. After bleeding the pump of air, check the oil pressure and adjust as required.
Test the combustion readings for; CO₂, smoke number and flue gas temperature. Adjust the air shutter as required.
Check the burner for lock-out function either by removing and covering the photoelectric cell or removing the solenoid coil.
Check the operation of the limit stat, by temporarily removing the control stat phial from its pocket. Reinststate all controls and run the boiler to confirm the operation of the control stat.
9. **SEALED SYSTEM.**
Check the sealed system pressure and water level. REFER TO SECTION 5.7. SYSTEM FILLING AND COMMISSIONING.
Check the operation of the pressure relief valve.
10. **FINALLY.** Advise the Householder of any problems.

FAULT FINDING

| | | |
|---|--|--|
| Initial user checks, before calling out a service engineer. If the boiler fails to start. • See also section 2. | | Action |
| Do you have enough fuel? | | Check the sight gauge. |
| Are all the fuel supply valves to the boiler open? | | See they are all open. |
| Has the external fire valve tripped? | | Press the trip button. |
| Is the boilers electrical power supply switched on? | | Check. |
| Has the boilers power supply fuse blown? | | Replace only once! |
| Are the heating system controls calling for heat? | | Set them for heating on. |
| Is the boiler control thermostat set between 1 and 6? | | Set for desired temperature. |
| Has the control panel high limit thermostat tripped? | | * Check and reset if required. |
| Has the burner control box gone to Lock-out? | | * Check and press lens. |
| If MHG Burner (blue flame - also see burner manual) | | |
| 10.1 | | |
| Problem | Probable causes | Actions / checks |
| 1. Burner will not start, or run | No power supply to the boiler. No power supply to the burner. Burner control box locked- out Burner motor / pump seized. | Switch the supply on. Isolator fuse may have blown. External heating system controls must call for heat: • Room thermostat. • Cylinder thermostat. • Programmer / time switch. Boiler control thermostat set between 1 and 6. Boiler limit thermostat tripped. Reset, press illuminated lens. Faulty photo-cell, replace. Faulty control box, replace. Look for oil leakage from pump shaft seal, replace if locked or tight spot. |
| 2. No fuel supply or restriction suspected | No fuel in tank. Supply lines restricted or blocked tank vent Air locks. | Replenish. Try to turn off oil at the burner, from the flexible oil line (gravity supply). Are all valves open, or has the fire valve tripped. Has the tank outlet valve tripped? Is there water in the tank or supply line? Are all the filters clean in supply oil pump. Has there a blockage in the supply line, at the inlet to a valve or deaerator? Rubber valve seats swollen with Kerosene contact. Air being drawn into suction supply line from valve heads or fittings, consider fitting deaerator. Bleed pump. |
| 3. Burner starts but locks-out after 15 secs | Dirty photo-cell. Control box photo-cell circuit faulty. Control box base connections loose. Restricted oil supply. Nozzle dirty. Combustion settings out of specification. | Clean cell and inside of blast tube. Replace control box. Tighten Check as above. Replace. Reset. |

| Problem | Probable causes | Actions / checks |
|--|--|---|
| <p>4. Burner starts but no flame establishes</p> | <p>Oil restriction. Blocked oil nozzle. No pump pressure.</p> <p>Motor / pump drive coupling broken. Ignition failure.</p> <p>Burner settings.</p> | <p>Check as above. Replace. Faulty pump solenoid coil replace. Dirt in pump, clean or replace. Replace.</p> <p>Check: electrode gap (3-4mm), arcing to the blast tube, condition of leads. Cracked ceramic insulator, replace electrode assembly. Low oil pressure or too much air adjustment.</p> |
| <p>5. Burner runs but continually pulsates</p> | <p>Condense trap blocked. Flue system blocked. Air supply restricted. Flue terminating into pressure zone. Nozzle worn, with poor spray pattern and high capacity. Nozzle dribble or letting by on shut-down. Boiler baffles wrongly positioned.</p> | <p>Check free flow of water from trap to outside.</p> <p>Check for debris or soot build-up, clean. Clear obstruction. Check flue height, if wrong consider increasing flue termination height. Replace.</p> <p>Check oil solenoid seat on pump, clean or replace pump valve assembly. See that the chamber is dry of oil. Relocate in correct order.</p> |
| <p>6. Morning lock- outs</p> | <p>Two pipe supply suction line losing oil. Oil level in tank below minimum level. Burner excess air too high. Burner stalling. Supply voltage low in mornings. Boiler output too large for system.</p> | <p>Check the non-return valve functions OK. Raise minimum tank height or fit deaerator.</p> <p>Set air setting for higher CO₂, (check smoke number). Check for tight or seized motor bearing. Is the pump shaft seal leaking oil? Seek advice from local electricity supplier. Check pump setting for correct temperature drop across boiler. Consider de-rating burner.</p> |
| <p>7. Burner runs but smokes</p> | <p>Tank topped up with wrong grade of fuel.</p> <p>Air supply restricted. Dust build-up on burner fan blades. Boiler flue-ways or flue restricted. Combustion dirty.</p> | <p>Check with fuel supplier.</p> <p>Clear obstruction. Brush blades clean.</p> <p>Check for debris and soot build-up, clean.</p> <p>Check and reset: Nozzle, CO₂, smoke number and pump pressure, reset as necessary.</p> |

| Problem | Probable causes | Actions / checks |
|--|--|---|
| 8. Burner runs OK, but flame shuts down slowly | Air entrapment in nozzle or pump. Solenoid valve faulty. Pump shut-off piston sticking. | Bleed pump, check for air ingress in suction line while running (two pipe system). Replace coil or stem assembly. Replace pump |
| 9. Burner runs but goes to lock-out before reaching temperature | Balanced flue system leaking combustion products into air supply. Combustion leaks at flue joints, covers or burner mounting. Suction line drawing air into fuel. | Use analyser to check for CO2 in burner air supply. If found to be leaking, resealing is essential. Check condition of gaskets, (typically open flued system). Check for air ingress at valves and fittings, consider fitting deaerator. |
| 10. Burner runs but does not reach working temperature | Boiler undersized for system. Burner output restricted. Low efficiency (high flue gas temperature) Faulty control thermostat. | Re-rate output if possible. Consider upgrade. Check nozzle output. If exchanger surfaces are sooty, clean. Check combustion settings. Replace. |
| 11. Fumes from boiler | Combustion leaks at flue joints, covers or burner mounting. Flue system not evacuating products of combustion. | Check condition of gaskets, reseal. Inspect flue for debris or soot build-up, check for flue spillage. |
| 12. Oil smells | Oil leakage at connections or fittings, or through braiding of hose. | Check for leaks or weeping at joints, inspect flexible hose and replace as required. |
| 13. Other problems | <ul style="list-style-type: none"> • Boiler cycling on limit thermostat. • Boiler blows fuses. • • White pluming at flue terminal. • Noise from burner. | <p>Replace control thermostat.</p> <p>Motor / pump seized, replace. Wiring short. Motor winding failed, replace.</p> <p>Not a boiler problem. This is associated with water vapour condensing into cold air.</p> <p>Fan rubbing on scroll, reposition.</p> <p>Motor bearings dry, due to oil leaking from pump shaft seal, replace.</p> |

10.3 Fault finding – Hot Water System.

| Problem | Probable causes | Actions / checks |
|---|---|--|
| 1. No Hotwater | Circulating pump seized. Programmer HW channel off. Hot water temperature stat switched off. Flow switch blocked or faulty. Inlet ball valve partially blocked, by debris build-up reducing flow rate to below flow switch trigger rate of 2.5l/m. Spring-return valve, seized or jammed 11 pin relay coil faulty. Programmer faulty. High limit thermostat | Free off rotor or replace. Advance or re-programme. Re-set or replace. Clear blockage or replace paddle head. open bleed screw, to blow-out dirt, or strip and clean. Check lever position, when powered Free valve or replace head. Replace relay. Replace. Reset. Check heating water circulating and possible air entrapment in thermal store or boiler. Check flow switch is stuck open or faulty. Circulating pump faulty, replace. CH or DHW thermostat faulty, replace. |
| 2. low water temperature and flow | Plate heat exchanger partially scaled up. Debris build-up behind flow control filter. Low water supply pressure. | De-scale or replace. Check function of water treatment. open bleed screw, to blow-out dirt, or strip and clean. Check pressure, if low report to water company. |
| 1. No CH and or DHW | Programmer channels for either CH or DHW are off. DHW and or CH thermostats set to off position or fault. | Advance or re-programme. Re-set or replace. |
| 2. High limit thermostat trips off | Circulating pump faulty. | Free off or replace. |
| 3. No CH (DHW OK) | Faulty spring return valve, not moving to operating mode. Room stat set low or faulty. | Check if lever is moving over, indicated by operating light, or replace head. Re-set or replace. |
| 4. No DHW (CH OK) | Faulty spring return valve, jammed in HW mode. Flow switch blocked or faulty. 11 pin relay faulty. | Check lever position, when powered SRV head shows operating light. Free valve or replace head. Clear blockage or replace paddle head. Replace relay. |
| 5. Pressure relief valve discharges. (HW and CH OK) | Pressure vessel has lost charge, or insufficient expansion volume. PRV faulty or dirty seating. | Check vessel charge, re-pressurise or replace if diaphragm damaged. Or add extra volume (see section 5.5). Clear dirt, or replace PRV. |

BOILER SPECIFICATION

Low Nox Yellow Flame NON CONDENSING

| Function | Key | Boiler Model Size | | | | | | | |
|--------------------------|----------|-------------------|---------------|---------------|---------------|-----------|-----------|-----------|--|
| Model Size/Type | | 1 | 2 | 3 | 4 | 5 | 6 | 7 | |
| Model/Output | Kw | 15/20 | 20/26 | 26/35 | 35/41 | 41/50 | 50/58 | 58/70 | |
| Model/Output | Btu/1000 | 50/70 | 70/90 | 90/120 | 120/140 | 140/170 | 170/200 | 200/240 | |
| Fuel | Kerosene | 28 sec | | | | | | | |
| Nozzel size STD EFF | Danfoss | .65 80 EH | .75/80 EH | .85/60 EH | 1.10/60 EH | 1.25/60 S | 1.50/60 S | 1.75/45 S | |
| Pump Pressure | Bar | 10 | 8.7 | 9 | 10 | 10 | 10 | 9.5 | |
| | PSI | 145 | 125 | 130 | 145 | 145 | 145 | 140 | |
| Co2 | % | 12.5 | | | | | | | |
| CO | PPM | <43 | | | | | | | |
| Smoke Number | <> | 0-1 | | | | | | | |
| Max Operating Pressure | Bar | 3 | | 300 KPA | | | | | |
| Test Pressure | Bar | 4.5 | | 450 KPA | | | | | |
| Min Static Head | Metres | 1 | | | | | | | |
| Burner Type | Riello | RDB 2.2 | RDB 2.2 | RDB 2.2 | RDB 2.2 | RDB 3.2 | RDB 3.2 | RDB 3.2 | |
| Head Setting | | 13.5 | 14.5 | 16.5 | 20.5 | | | | |
| Air Disc Setting | | C | C | N/A | N/A | | | | |
| Blast Tube | Pattern | BX 15-20 | BX 20-26 | BX 26-35 | BX 35-41 | G5 | G5 | BT | |
| Blast Tube Setting | Position | Recirculation | Recirculation | Recirculation | Recirculation | 1 | 3 | 3 | |
| NOX - mg/kwh | Maximum | 120 | | | | | | | |
| Balanced Flue Diameter | OD mm | 125 | | | | 150 | | | |
| Flue Gas Temperature | °C | 150+ | | | | | | | |
| Minimum Draught | Ins/WG | 0.10 | | | | | | | |
| | Ins/WG | 0.04 | | | | | | | |
| Maximum Draught | Mbar | 0.37 | | | | | | | |
| | Ins/WG | 0.15 | | | | | | | |
| Min Return Temp | °C | 50 | | | | | | | |
| Max Operating Temp | °C | 82 | | | | | | | |
| Min Operating Temp | °C | 55 | | | | | | | |
| Hearth Temp | °C | Less Than 80 | | | | | | | |
| Limit Thermostat Temp | °C | 110 Manual Reset | | | | | | | |
| Flow & Return Difference | °C | 10 - 20 | | | | | | | |
| Water Resistance 10°C | mm/WG | <300 | | | | | | | |

1/ For safety and to ensure correct function before the boiler is put into use, the boiler, burner and system must be commissioned by a suitably qualified engineer.

2/ These figures are for guide purposes only and are based on what we consider the boiler's optimum range setting to maintain a clean running system.

3/ Site conditions, the flue and the overall installation can have an effect on the boiler set up, requiring further adjustment to achieve the most efficient combustion.

For Non Condensing boilers it is preferable for the flue gases to exceed 150°C. In order to achieve this, some baffles may have to be removed.

4/ Flue type and lengths, especially elbows and horizontal runs, add resistance to the boiler through draft, which can occasionally cause over pressurisation in the chamber. Wind direction and the flue terminal position can also have an influence on this. If this is found to be the case, it may be necessary to downsize the nozzle to restore and correct the balance of air flowing through the boiler.

5/ Generally speaking, boilers are usually set at mid range. On the low NOx boilers, there is a small loss of maximum output of about 4% on the 35/41 kW and the 58/70 kW. Please contact us if this is a problem.

6/ The above data is collated from tests completed on Mistral HE and SE range of boilers.

7/ During the setting up of Outdoor Boilers the Door and Lid of the Boiler should be fitted and test conducted from the end of the flue.

LOW NOX BURNERS

| BOILER SPECIFICATION | | Low Nox Yellow Flame | | | | | | | |
|--------------------------|----------|----------------------|---------------|---------------|---------------|-----------|-----------|----------|--|
| Function | Key | Boiler Model Size | | | | | | | |
| Model Size/Type | | 1 | 2 | 3 | 4 | 5 | 6 | 7 | |
| Model/Output | Kw | 15/20 | 20/26 | 26/35 | 35/41 | 41/50 | 50/58 | 58/70 | |
| Model/Output | Btu/1000 | 50/70 | 70/90 | 90/120 | 120/140 | 140/170 | 170/200 | 200/240 | |
| Fuel | Kerosene | 28 sec | | | | | | | |
| Nozzle Size | Danfoss | .50/80°EH | .65/80°EH | .85/60°EH | 1.10/60°EH | 1.25/60°s | 1.50/60°s | 1.75/45s | |
| Pump Pressure | Bar | 10 | 8.7 | 9 | 10 | 10 | 10 | 9.5 | |
| | PSI | 145 | 125 | 130 | 145 | 145 | 145 | 140 | |
| Co2 | % | 12.5 | | | | | | | |
| CO | PPM | <43 | | | | | | | |
| Smoke Number | <> | 0-1 | | | | | | | |
| Max Operating Pressure | Bar | 3 | | | | | 300 KPA | | |
| Test Pressure | Bar | 4.5 | | | | | 450 KPA | | |
| Min Static Head | Metres | 1 | | | | | | | |
| Burner Type | Riello | RDB 2.2 | RDB 2.2 | RDB 2.2 | RDB 2.2 | RDB 3.2 | RDB 3.2 | RDB 3.2 | |
| Head Setting | | 12.5 | 13.5 | 16.5 | 20.5 | | | | |
| Air Disc Setting | | B | C | N/A | N/A | | | | |
| Blast Tube | Pattern | BX 15-20 | BX 20-26 | BX 26-35 | BX 35-41 | G5 | G5 | BT | |
| Blast Tube Setting | Position | Recirculation | Recirculation | Recirculation | Recirculation | 1 | 3 | 3 | |
| NOX - mg/kwh | Maximum | 120 | | | | | | | |
| Balanced Flue Diameter | OD mm | 125 | | | | 150 | | | |
| Flue Gas Temperature | °C | 50 - 115 | | | | | | | |
| Minimum Draught | Ins/WG | 0.10 | | | | | | | |
| | Ins/WG | 0.04 | | | | | | | |
| Maximum Draught | Mbar | 0.37 | | | | | | | |
| | Ins/WG | 0.15 | | | | | | | |
| Min Return Temp | °C | 50 | | | | | | | |
| Max Operating Temp | °C | 82 | | | | | | | |
| Min Operating Temp | °C | 55 | | | | | | | |
| Hearth Temp | °C | Less Than 80 | | | | | | | |
| Limit Thermostat Temp | °C | 110 Manual Reset | | | | | | | |
| Flow & Return Difference | °C | 10 - 20 | | | | | | | |
| Water Resistance 10°C | mm/WG | <300 | | | | | | | |

1/ For safety and to ensure correct function before the boiler is put into use, the boiler, burner and system must be commissioned by a suitably qualified engineer.

2/ These figures are for guide purposes only and are based on what we consider the boilers optimum range setting to maintain a clean running system.

3/ Site conditions, the flue and the overall installation can have an effect on the boiler set up, requiring further adjustment to achieve the most efficient combustion.

For Non Condensing boilers it is preferable for the flue gases to exceed 150°C. In order to achieve this, some baffles may have to be removed.

4/ Flue type and lengths, especially elbows and horizontal runs, add resistance to the boiler through draft, which can occasionally cause over pressurisation in the chamber. Wind direction and the flue terminal position can also have an influence on this. If this is found to be the case, it may be necessary to downsize the nozzle to restore and correct the balance of air flowing through the boiler.

5/ Generally speaking, boilers are usually set at mid range. On the low nox boilers, there is a small loss of maximum output of about 4% on the 35/41 kw and the 58/70 kw. Please contact us if this is a problem.

6/ The above data is collated from tests completed on Mistral HE and SE range of boilers.

7/ During the setting up of Outdoor Boilers the Door and Lid of the Boiler should be fitted and test conducted from the end of the flue.

BOILER SPARES

Control Panel Components

| Item | Description | 15-41 KW | 41-68 KW |
|------|-------------------------------------|------------|------------|
| 1 | Control Knob and Bezel | CK1568 001 | CK1568 001 |
| 2 | Control Thermostat / DHW Thermostat | CK1568 002 | CK1568 002 |
| 3 | Manual Reset Button Cover | CK1568 003 | CK1568 003 |
| 4 | Manual Reset Limit thermostat | CK1568 004 | CK1568 004 |
| 5 | Dual Channel programmer (Combi) | CPRG 2 | CPRG 2 |
| 6 | 11 pin relay (combi) | CC1568 001 | CC1568 001 |
| 7 | 11 pin relay base (combi) | CC1568 002 | CC1568 002 |
| 8 | Pump over run thermostat (combi) | CK1568 017 | CK1568 017 |
| 9 | 6 pin immersion relay (combi Plus) | CC1568 004 | CC1568 004 |

Combi / Utility and Sealed System Boiler Components

| | | | |
|----|---------------------------------|------------|------------|
| 5 | Circulating Pump | CC1541 005 | CC4168 005 |
| 6 | 12 Litre Expansion Vessel | CC1541 006 | CC4168 006 |
| 7 | Pressure Gauge (0-4 bar) | CC1568 007 | CC1568 007 |
| 8 | Pressure Relief Valve (0-3 Bar) | CC1568 008 | CC1568 008 |
| 9 | Auto Air Vent | CC1568 019 | CC1568 019 |
| 10 | Expansion Vessel Hose | CY1568 030 | CY1568 030 |
| 11 | Filling loop Kit | CC1568 999 | CC1568 999 |
| 12 | Pump Valve | CC1541 006 | CC4168 006 |
| 13 | Diverter valve | CC1541 002 | CC4168 002 |
| 15 | Flow switch | CC1568 003 | CC1568 003 |

Boiler Heat Exchanger Short Spares

| | | | |
|----|---|------------|------------|
| 13 | Condensing Unit Baffles | CY1568 013 | CY1568 013 |
| 14 | Top Left Hand Side Baffle | CY1541 014 | CY4168 014 |
| 15 | Top Right Hand Side Baffle | CY1541 015 | CY4168 015 |
| 16 | Middle Left Hand Side Baffle | CY1541 016 | CY4168 016 |
| 17 | Middle Right Hand Side Baffle | CY1541 017 | CY4168 017 |
| 18 | Bottom Left Hand Side Baffle | CY1541 018 | CY4168 018 |
| 19 | Bottom Right Hand Side Baffle | CY1541 019 | CY4168 019 |
| 20 | Condense Trap | CTR 005 | CTR 005 |
| 21 | Front Access Cover Assembly Main Heat Exchanger | CY1541 018 | CY4168 018 |
| 22 | Front Access Cover Assembly Condensing Heat Exchanger | CY1541 700 | CY4168 700 |
| 23 | Condensing unit door seal | CY1541 020 | CY4168 020 |
| 24 | Base Pad | CY1541 021 | CY4168 021 |

Boiler Casing Set

| | | |
|----|------------|----------------|
| 24 | Casing Set | On Application |
|----|------------|----------------|

Short Burner Spares List. Riello RDB1/2/3 (for blue flame burner see burner manual)

| | | |
|----|------------------------|-----------------------|
| 25 | Flexible Air Hose (BF) | Riello CK4001 022 |
| 26 | Air Hose Clips (BF) | CK4001 023 |
| 27 | Control Box | MBR 102 |
| 28 | Photo Electric Cell | MBR 105 |
| 29 | Motor | MBR 100 |
| 30 | Capacitor | MBR 104 |
| 31 | Pump | MBR 101 |
| 32 | Solenoid Coil | MBR 103 |
| 33 | Mounting Flange | MBR 129 (Sate Burner) |
| 34 | Flange Gasket | MBR 130 |
| 35 | Blast Tube | MBR (State Burner) |
| 36 | Flexible Oil Line | MBR 132 |

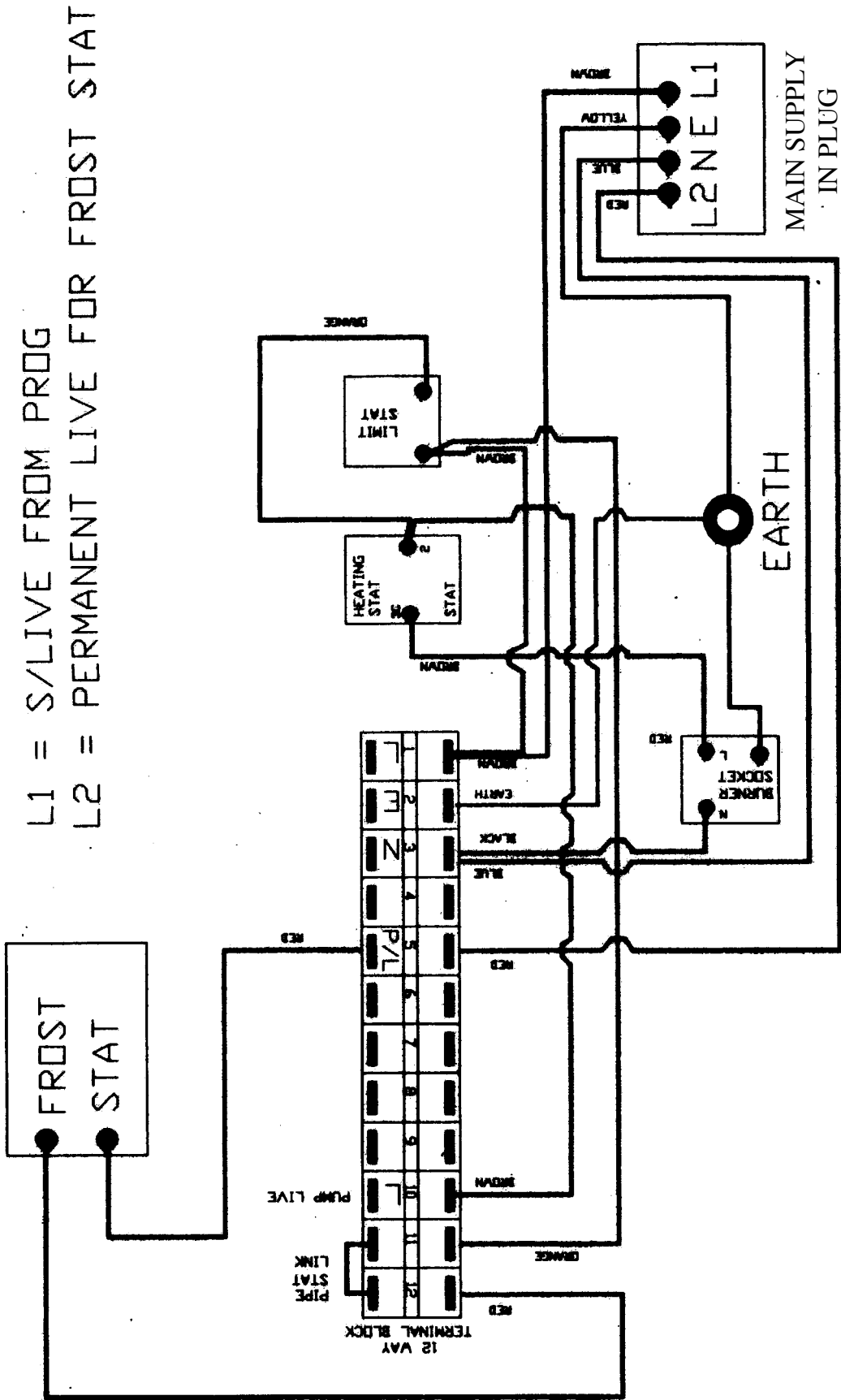

13.1 Combi Standard and Plus Control Panel Components Diagram with wiring removed.

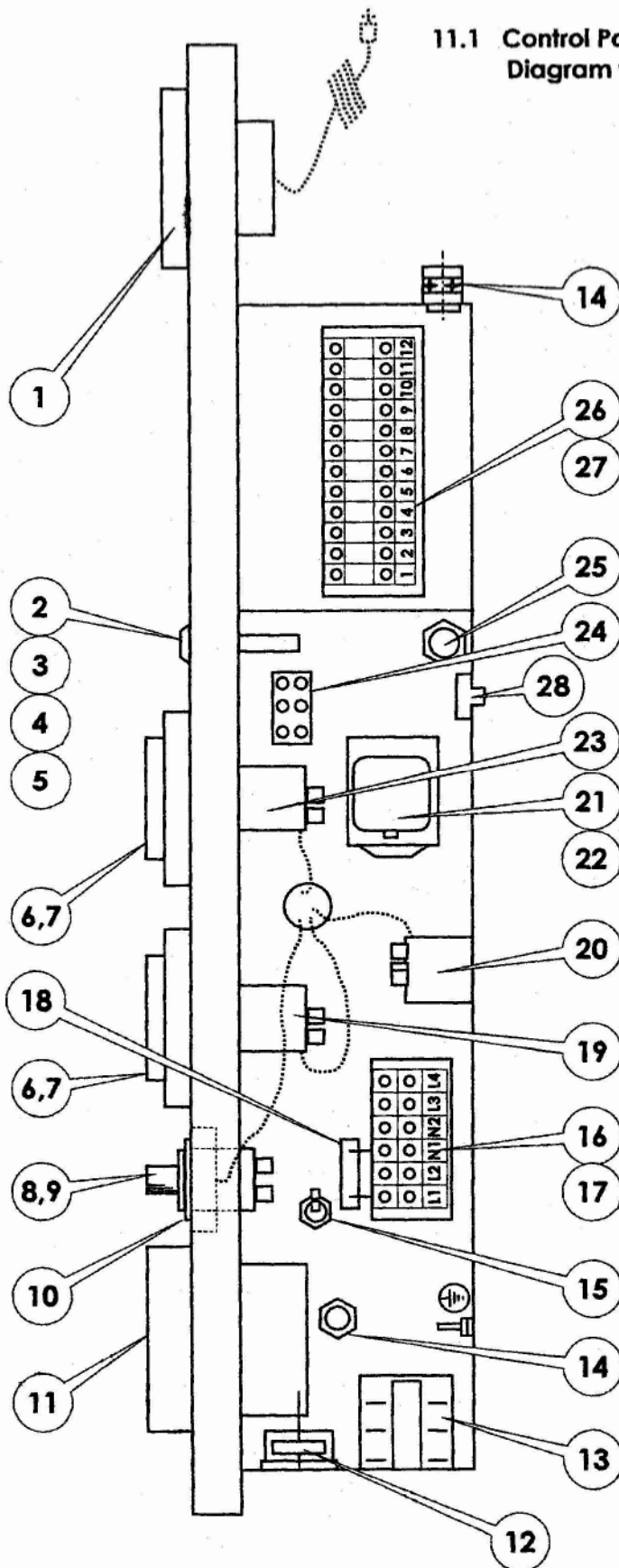

11.1 Control Panel Components Diagram with wiring removed

| Item | Description |
|------|---|
| 1 | Pressure gauge 0 - 4bar |
| 2 | Green neon 230v |
| 3 | Clear neon 230v |
| 4 | Amber neon 230v |
| 5 | Red neon 230v |
| 6 | Mistral thermostat knob |
| 7 | Bezel |
| 8 | Limit thermostat reset button cover |
| 9 | Limit thermostat 110°C |
| 10 | Selector switch |
| 11 | Programmer 2 channel |
| 12 | Electrical Supply in socket male & female |
| 13 | Relay 20amp (immersion heater) |
| 14 | Cable grip 16mm |
| 15 | Fuse holder (5amp fuse) |
| 16 | 6 way terminal strip |
| 17 | 6 way ident shield |
| 18 | Capacitor 0.47µF |
| 19 | Heating control thermostat |
| 20 | Pump overrun thermostat |
| 21 | 11 pin relay |
| 22 | Relay base |
| 23 | Hot water control thermostat |
| 24 | Burner socket |
| 25 | Cable grip 20mm |
| 26 | 12 way terminal strip |
| 27 | 12 way ident shield |
| 28 | Limiting Stat |

COMBI PLUS WIRING DIAGRAM

Refer to Page 17-18 4.4

MAIN SUPPLY
IN PLUG

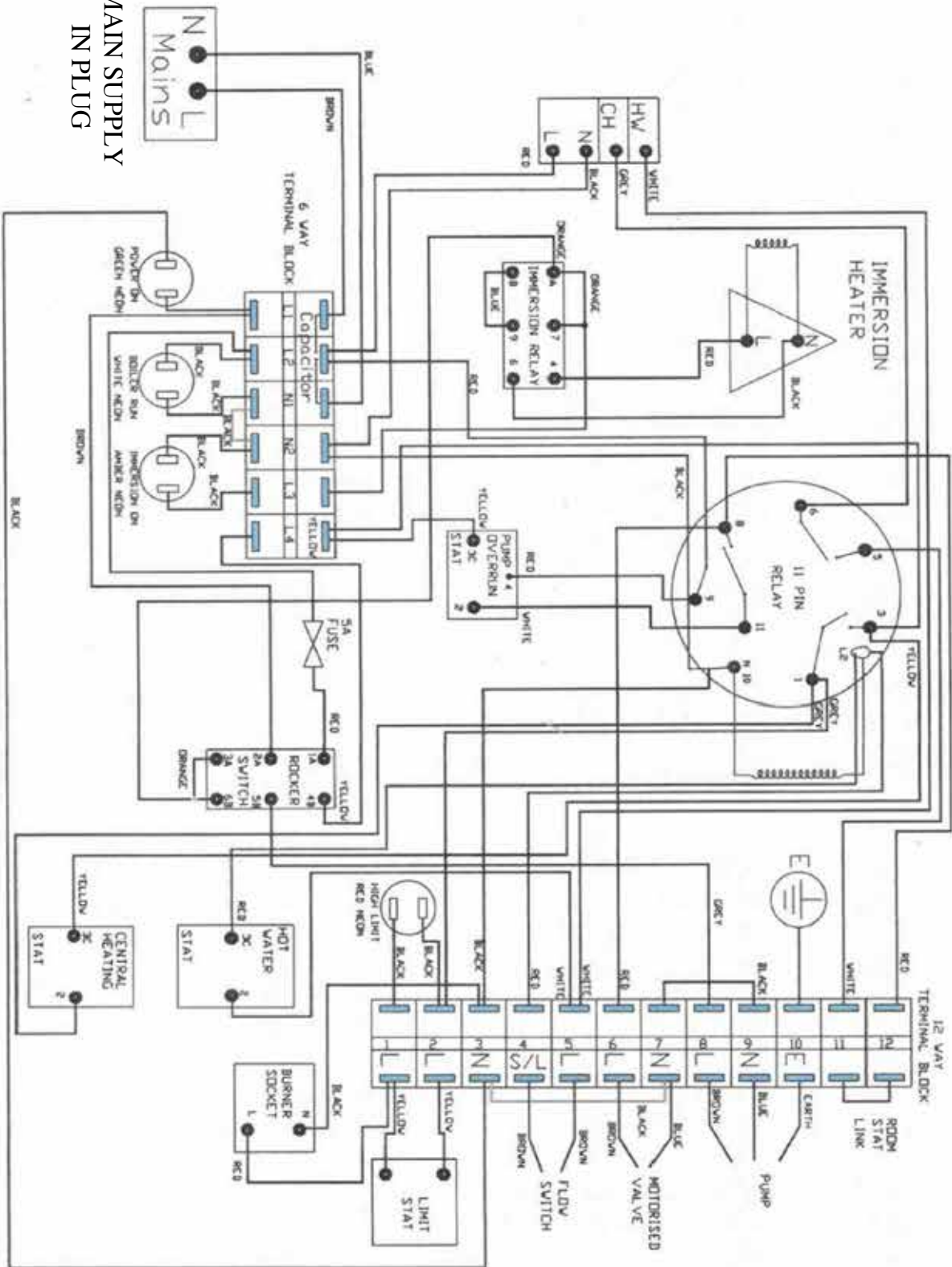

COMBI STANDARD WIRING DIAGRAM

Refer to Page 17-18 4.4

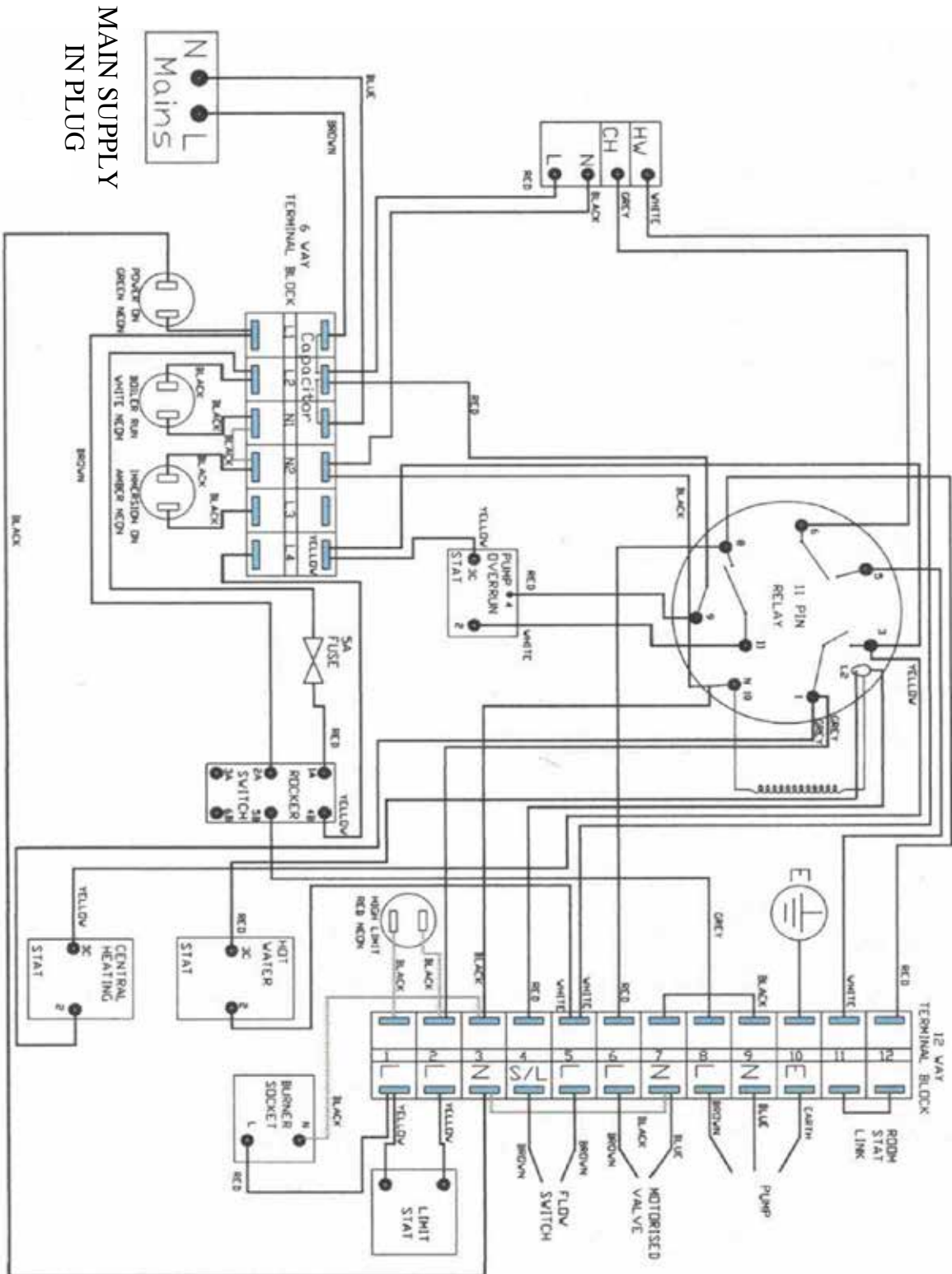

WIRING OF EXTERNAL PROGRAMMER ON COMBI BOILER

Fitting of two Channel programmer

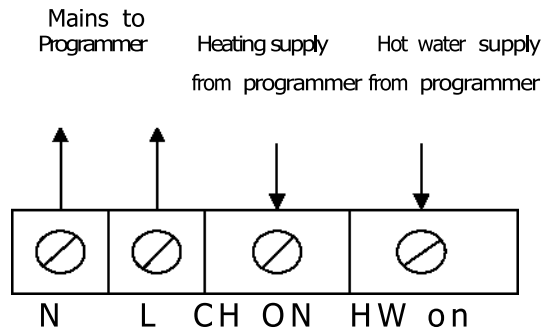

Fitting of Single Channel programmer
NOT RECOMMENDED

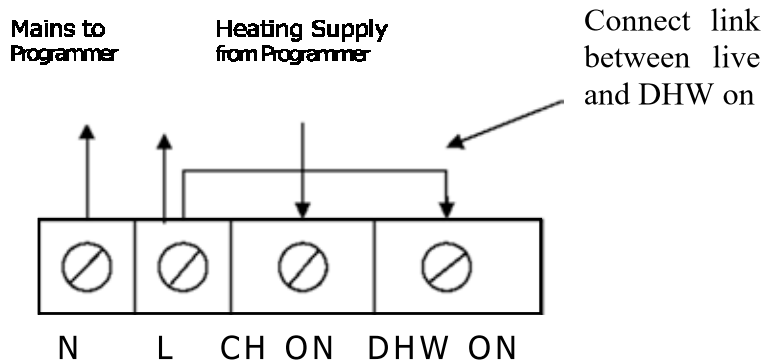

Connect links For test only

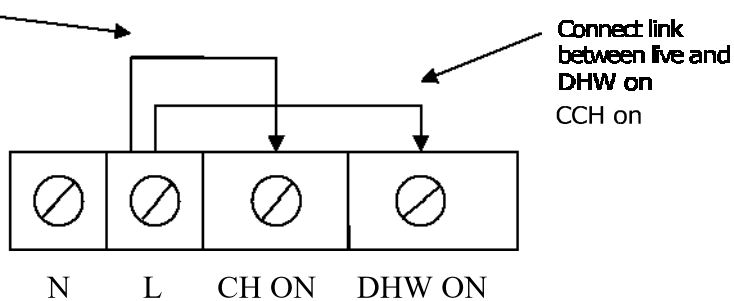

Wiring of external room stat

11 = L to stat

12 = S/L from stat to boiler

Do not use an externally powered room stat

A room stat can be connected to all combi models
Connections are No 11 & 12 on the 12 way strip

INSTALLATION/COMMISSIONING/SERVICE & WARRANTY DETAIL

Installation, Commissioning & Service Record

Installer Contact Details

Engineers Name: CD 10 Number:
 Company Name: Installation Date:
 Address:
 Postcode: Tel: Mob Tel:

Commissioning Engineer Details

Engineers Name: CD 11 Number:
 Company Name: Reg. Number:
 Address: Commissioning Date:
 Postcode: Tel: Mob Tel:
 Boiler Model: Output: Serial Number:
 Burner Model: Pump Pressure: **Checked**
 Oil Type: Air: Flue Seal / Gasket: Yes/No
 Nozzle Type: smoke Reading: Isolation Valves Fitted: Yes/No
 Nozzle Size: CO2%: Inhibitor In System: Yes/No
 Nozzle Pattern: F.G.T.*C: All Connections: Yes/No

Service Record

The information as recorded here should also be included in the engineers own report. To comply with the boilers Conditions of Guarantee the boiler must be serviced by a certified oil engineer at least once a year.

| | Service 1 | Service 2 | Service 3 | Service 4 |
|-----------------------------------|----------------|----------------|----------------|----------------|
| Engineers Name: | | | | |
| Company Name: | | | | |
| Certificate Number: Company Name: | | | | |
| Telephone Number: | | | | |
| | | | | |
| Nozzle Type: | | | | |
| Nozzle Size: | | | | |
| Nozzle Pattern: | | | | |
| Pump Pressure: | | | | |
| Air: | | | | |
| Smoke Reading ppm: CO2%: | | | | |
| F.G.T.*C: | | | | |
| | Checked | Checked | Checked | Checked |
| Flue Seal: | | | | |
| Gaskets: | | | | |
| Condense Trap: | | | | |
| Water: | | | | |
| Inhibitor Present: | | | | |
| All Connections: | | | | |
| Baffles: | | | | |
| Correct Baffle Position: | | | | |
| D.M. Hot Water: | | | | |
| Central Heating: | | | | |
| Flow Switch: | | | | |
| Power Supply: | | | | |
| | | | | |
| Date Of Service: | | | | |
| Signature: | | | | |

Guarantee Registration

Please detach here and forward to Mistral Boilers Ltd.

| Office Use Only | |
|------------------|--|
| Serial No: | |
| Registration No: | |

Mistral Boiler Guarantee Registration

To endorse the guarantee this form must be completed by the Installation Engineer, the Commissioning Engineer and the Householder. The completed document must be forwarded to Mistral Energy Products Ltd. Unit D4, Halesfield 23, Telford, Shropshire TF7 4NY within 28 days following the commissioning date. On receipt Mistral Energy Products will endorse the guarantee and issue the boiler with a Guarantee Registration Number. The householder will be advised of the Guarantee Registration Number upon receipt of this form.

The Guarantee Registration Number should be recorded in the Installation Manual as this will be required if it is necessary to make a claim during the warranty period.

Please complete all information fields using **BLOCK CAPITALS**

Householder Details

Customer Name:
 Customer Address:
 Address:
 Postcode: Tel: Purchase Date:

Installer Contact Details

Engineers Name:
 Engineers Address:
 Address:
 Postcode: Tel: Installation Date:
 Mob: CD 10 Number:

Commissioning Engineer Details

Engineers Name:
 Engineers Address:
 Address:
 Postcode: Tel: Commissioning Date:
 Mob: Reg Number:

Boiler Model: Output: Serial Number:

| | | |
|-----------------------|--------------------------|-----------------------------|
| Burner Model: | Pump Pressure: | Checked |
| Oil Type: | Air: | Flue Seal Checked: Yes/No |
| Nozzle Type: | Smoke Reading: | Gaskets Checked: Yes/No |
| Nozzle Size: | CO ² %: | Inhibitor In System: Yes/No |
| Nozzle Pattern: | F.G.T°C: | All Connections: Yes/No |

I certify that the above boiler has been installed and commissioned in accordance with the manufacturer's installation/instruction manual, the CD10 & CD11 documents are present and that all required checks have been completed ready for the safe operation of the boiler.

Commissioning Engineers Signature:

Mistral Energy Products Guarantee

1. The Mistral Terms Of Guarantee

Mistral Products are Guaranteed (Subject to Conditions) to be free from defective parts and workmanship from the date of purchase for the following time periods.

Guarantee only applies to products purchased and used in mainland UK. Boilers sold outside the UK Mainland are covered by a parts only policy. Parts to be returned within stated guarantee period.

a: Mistral Guarantee for the period of 1 Year.

The burner (excluding consumables) The plate heat exchanger, controls, valves, pumps and all other parts used in the manufacture of the boiler have a one year warranty.

b: Mistral Guarantee for the period of 5 Years.

Main Boiler steel heat exchanger (excluding baffles).

c: Warranty Extension.

Additional and extended boiler warranty schemes are available, details are available upon request.

2. Conditions Of Guarantee

a: The boiler must be installed by a suitably qualified person and the CD10 installation documentation completed. Prior to operation, the boiler must be commissioned by a certified oil engineer and the CD11 commissioning documentation completed. All work must be completed in accordance with the boiler installation manual and comply with all relevant Standards and Codes of Practice.

b: Following the boiler commissioning, to endorse the first year guarantee period, the commissioning engineer must complete the installation checklist in the manual and the householder must forward it to Mistral Energy Products Ltd. within 28 days. On receipt, Mistral will endorse the guarantee and advise the householder of the guarantee registration number. If the householder does not receive this within 28 days of submission, Mistral must be notified immediately.

c: The boiler is required to be serviced within each 12 month period from installation by a certified oil engineer and a

copy invoice sent to us. On receipt, we will again endorse this with a new guarantee registration number for that year. If within 28 days of supplying this information, you have not had a response from us, please notify us immediately.

3 General Terms of Reference

- a: Mistral will accept no liability in respect of any defect arising from incorrect installation, misuse, negligence, fair wear & tear, repair by unqualified persons or unauthorised modification.
- b: Mistral will not accept any liability for a defect occurring in the steel heat exchanger or any other part caused by the build up of lime scale, lack of a suitable inhibitor, air build up, low water level or low water return temperature.
- c: The guarantee extends to cover reasonable labour costs specific to a repair during the 1st year period. This is not available on products sold outside mainland UK. All other labour costs will be the responsibility of the householder. In the event of a defect with the boiler steel heat exchanger outside the 1st year period, the unit must be returned at the householders cost to Mistral Energy Products Ltd for inspection. A repair or replacement unit will then be supplied as applicable.
- d: Prior to any warranty repair or inspection work taking place a warranty authorisation number must be obtained from Mistral Energy Products Ltd.
- e: Any parts removed (that are subject to a warranty claim), must be returned to Mistral Energy Products Ltd within 28 days for testing and inspection.
- f: Mistral Energy Products Ltd. accepts no responsibility for any consequential repair, loss or damage however caused. Any additional work required such as unit removals, drain downs, filling or any other work that is consequential to the repair will be the sole responsibility of the householder.

THE STATUTORY RIGHTS OF THE OWNER ARE NOT AFFECTED BY THIS GUARANTEE

WARRANTY BREAKDOWN PROCEDURE

In the first instance if a fault is suspected, the householder must at their cost employ an engineer to inspect the complete heating system and fuel supply.

In the unlikely event of a boiler fault, the boiler should be made safe in all aspects. If a leak is suspected, all oil/water flow and return pipes to the boiler must be isolated. It is the responsibility of the householder/engineer to take all necessary action to make the boiler safe and ensure consequential damage limitation.

If a boiler problem is diagnosed the householder should contact Mistral Energy Products Ltd preferably whilst the engineer is attending. If the problem reported is subject to a potential warranty claim it will be necessary to provide details of the following:

1. Boiler Model Type & Serial Number
2. Date Of Purchase (Copy Of Sales Invoice)
3. CD10 Installation Number
4. CD11 Commissioning Number
5. Mistral Guarantee Number
6. Service History Log

If the claim is accepted by Mistral Energy Products as a potential warranty issue, a works authorisation number will be

issued for a specific repair to be completed either by the attending engineer or an appointed Mistral Technician.

Prior to the commencement of any work, Mistral Energy Products Ltd will require the authority and acceptance from the householder/engineer that all or any work completed will be chargeable in full if a fault is found not to be acceptable as a warranty claim.

Parts removed that are the subject of a warranty claim must be returned with the warranty claim invoice.

Mistral will not accept any invoice or charge for unauthorised or non acceptable warranty work. Any other costs will be the sole responsibility of the householder/engineer.

BOILER INFORMATION

Please record the following information.

Model Type

Serial Number.....

Date Of Purchase.....

CD10 Number.....

CD11 Number.....

Mistral Guarantee Number.....

Note: Mistral Energy Products will accept no claims for a warranty repair unless a full payment for the product or any prior work completed on the product has been received in full and in accordance to Mistral Energy Products Ltd Terms & Conditions of sale.

Mistral are one of the longest standing manufacturers of oil fired boilers and associated products in the UK.

It is our Company policy to create continual improvement, and as such, are always open to new ideas. We also strive to source and purchase all our materials from the UK, wherever possible. If you require any more advice or guidance on any of our products, please feel free to contact our customer service department.

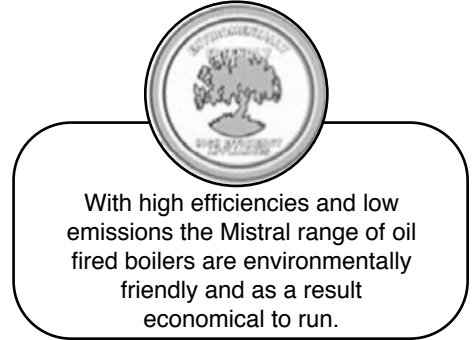
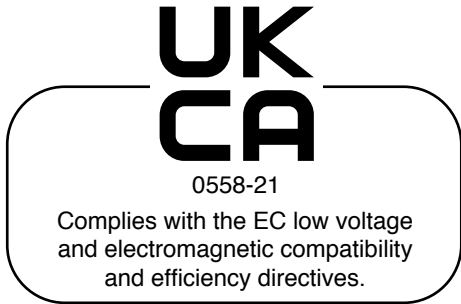

**British Made
Quality
Products**

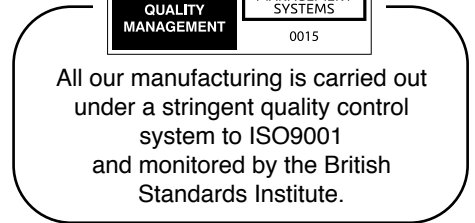

Our sales / technical / customer services department will be pleased to assist and advise on all our products and associated components.

Tel: 01952 270082
sales@mistralproducts.com

Fax: 01952 270086
www.mistralboilers.com
www.mistralproducts.com



Mistral Energy Products Ltd, Unit D4, Halesfield 23,
Telford, Shropshire TF7 4NY

Mistral Energy Products Ltd maintain a policy of continuous product improvement and in order to stay at the forefront of boiler technology reserves the right to alter specifications without notice. The statutory rights of the consumer are not affected. All information correct at time of going to press. Terms & Conditions of Warranty are available on request.